

Display Elektronik GmbH

DATA SHEET

TFT MODULE

DEM 320240M1 VTH-PW

2,0“ transfl. TFT

Product Specification

Version: 0

14.10.2024

Contents

- 1. Block Diagram..... 5
- 2. Outline dimension..... 6
- 3. Input terminal Pin Assignment..... 7
- 4. LCD Optical Characteristics 9
 - 4.1 Optical specification10
- 5. Electrical Characteristics 11
 - 5.1 Absolute Maximum Rating.....11
 - 5.2 DC Electrical Characteristics.....12
 - 5.3 LED Backlight Characteristics12
- 6. AC Characteristics 14
 - 6.1 Display Parallel 8/9/16/18-bit Interface Timing Characteristics (8080 system).....14
 - 6.2 Display Serial Interface Timing Characteristics (3-line SPI system).....17
 - 6.3 Display Serial Interface Timing Characteristics (4-line SPI system).....18
 - 6.4 Parallel 16/18BIT RGB Interface Timing Characteristics19
 - 6.5 RGB Interface Timing.....20
 - 6.6 Reset Timing Characteristics22
- 7. LCD Module Out-Going Quality Level 23
 - 7.1 VISUAL & FUNCTION INSPECTION STANDARD23
 - 7.1.1 Inspection conditions24
 - 7.1.2 Definition24
 - 7.1.3 Sampling Plan25
 - 7.1.4 Criteria (Visual).....26
- 9. Cautions and Handling Precautions 30
 - 9.1 Handling and Operating the Module30
 - 9.2 Storage and Transportation.....30

*** Description**

This is a color active matrix TFT (Thin Film Transistor) LCD (liquid crystal display) that uses amorphous silicon TFT as a switching device. This module is composed of a transfective type TFT-LCD Panel, driver circuit, back-light unit. The resolution of a 2.0 " TFT-LCD contains 320x240 pixels, and can display up to 65K/262K colors.

*** Features**

General Information Items	Specification	Unit	Note
	Main Panel		
Display area(AA)	40.80(H)*30.60(V) (2.0 inch)	mm	
Driver element	TFT active matrix	-	
Display colors	65K/262K	colors	
Number of pixels	320(RGB)*240	dots	
Pixel arrangement	RGB vertical stripe	-	
Pixel pitch	0.1275(H)*0.1275(V)	mm	
Viewing angle	Wide angle	o'clock	
Controller IC	ILI9342C	-	
LCM Interface	8/9/16/18Bit MCU 3/4SPI+16/18Bit RGB Interface 3-line/4-line Serial	-	
Display mode	Transflective /Normally Black	-	
Operating temperature	-20~+70	°C	
Storage temperature	-30~+80	°C	

*** Mechanical Information**

Item		Min.	Typ.	Max.	Unit	Note
Module size	Horizontal(H)	-	46.50	-	mm	
	Vertical(V)	-	41.56	-	mm	
	Depth(D)	-	2.70	-	mm	
Weight		-	10	-	g	

1. Block Diagram

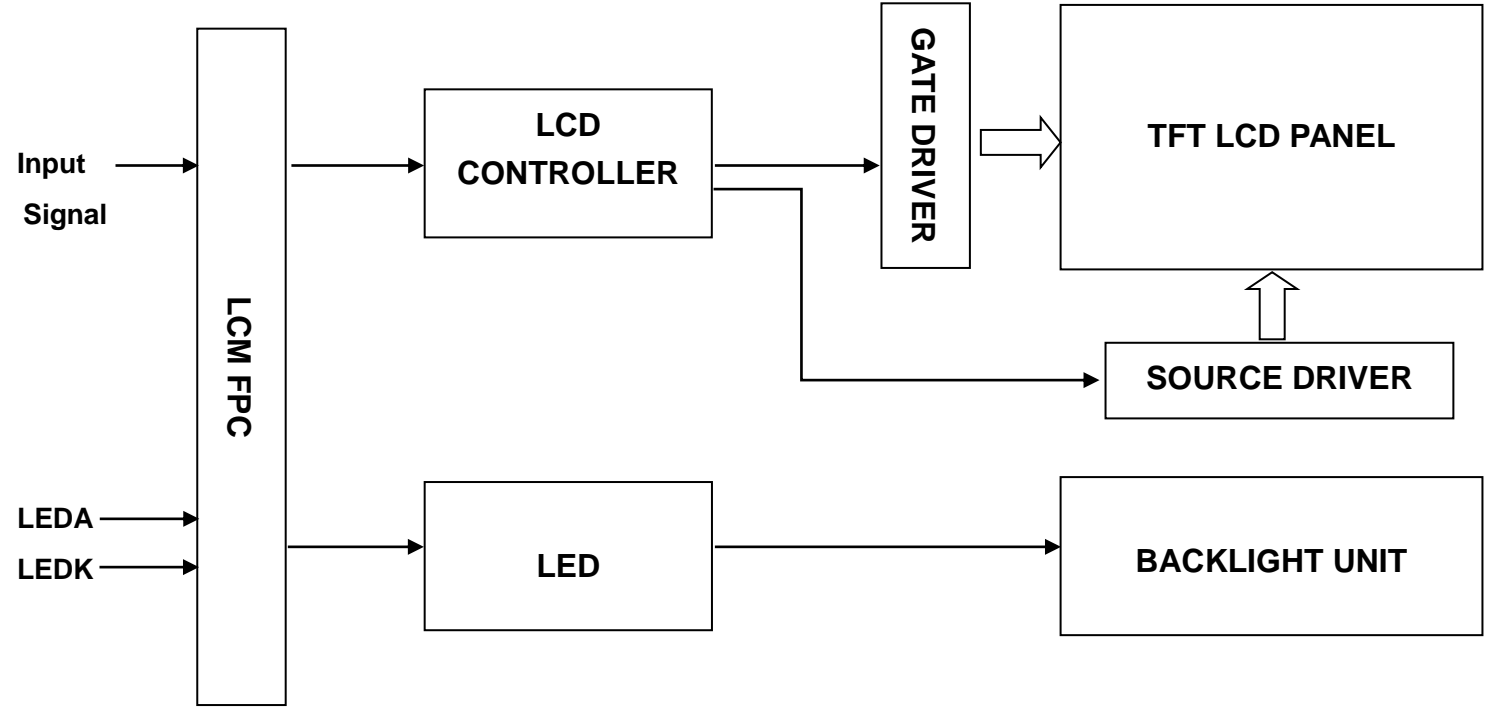

2. Outline Dimension

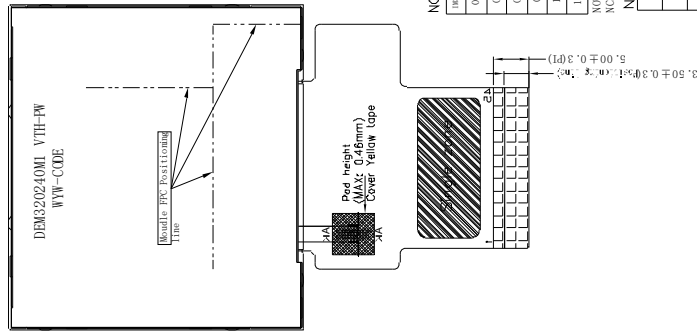
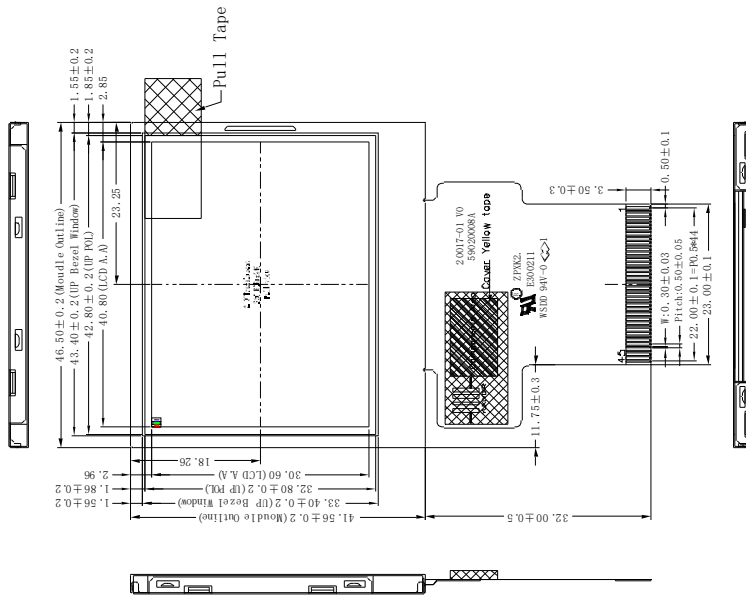

NOTE: MCU interface SET for IM PINS

DB15	DB14	Interface Type	DB Pin to use
0	0	DB15-16-bit interface	DB15-DB00
0	1	DB15-16-bit interface	DB15-DB00
0	0	DB15-16-bit interface	DB15-DB00
0	1	DB15-16-bit interface	DB15-DB00
1	0	DB15-16-bit interface	DB15-DB00
1	1	DB15-16-bit interface	DB15-DB00
1	1	DB15-16-bit interface	DB15-DB00
1	1	DB15-16-bit interface	DB15-DB00

NOTE: RGB Interface

RGB Interface	DB Pin to use
16 Bit RGB Interface	DB15-DB00
18 Bit RGB Interface	DB15-DB00

NOTE: If used RGB mode must select serial interface!

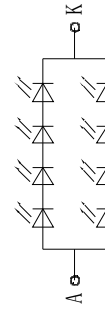

B/L Circuit

NOTE:

1. DISPLAY TYPE: 2.0", TFT-LCD, 65K/262K COLORS
2. DISPLAY MODE: NORMALLY BLACK, TRANSPARENT
3. VIEWING DIRECTION: WIDE VIEWING
4. LCM DRIVER IC: ILI9342C (COG)
LCM Interface: 3/4Serial, 8/9/16/18BIT MCU
3/4SPI+16/18BIT RGB
5. VDD: 3.3V (TYP.), IOVCC: 1.8-3.3V
6. OPERATING TEMP: -20° C TO 70° C
STORAGE TEMP: -30° C TO 80° C
7. BACK LIGHT: LED WHITE, 8 LED, 40mA, 12.0±0.3V
8. RoHS COMPLIANT.

3. Input terminal Pin Assignment

NO.	SYMBOL	DISCRIPTION	I/O																																			
1	GND	Ground.	P																																			
2	GND	Ground.	P																																			
3	IOVCC	Supply voltage(1.65-3.3V)	P																																			
4	VCI	Supply voltage(3.3V).	P																																			
5	IM3	Interface Selection <table border="1"> <thead> <tr> <th>IM3</th> <th>IM2</th> <th>IM0</th> <th>Interface type</th> <th>DB Pin in use</th> </tr> </thead> <tbody> <tr> <td>0</td> <td>0</td> <td>0</td> <td>DBI Tyb_ 8-bit interface</td> <td>DB7-DB0</td> </tr> <tr> <td>0</td> <td>1</td> <td>0</td> <td>DBI Tyb_ 16-bit interface</td> <td>DB15-DB0</td> </tr> <tr> <td>0</td> <td>0</td> <td>1</td> <td>DBI Tyb_ 9-bit interface</td> <td>DB8-DB0</td> </tr> <tr> <td>0</td> <td>1</td> <td>1</td> <td>DBI Tyb_ 18-bit interface</td> <td>DB17-DB0</td> </tr> <tr> <td>1</td> <td>0</td> <td>1</td> <td>3-Wire 9 BIT data serial interface.</td> <td>SDA SCL CS</td> </tr> <tr> <td>1</td> <td>1</td> <td>1</td> <td>4-Wire 8 BIT data serial interface</td> <td>SDA SCL CS RS</td> </tr> </tbody> </table>	IM3	IM2	IM0	Interface type	DB Pin in use	0	0	0	DBI Tyb_ 8-bit interface	DB7-DB0	0	1	0	DBI Tyb_ 16-bit interface	DB15-DB0	0	0	1	DBI Tyb_ 9-bit interface	DB8-DB0	0	1	1	DBI Tyb_ 18-bit interface	DB17-DB0	1	0	1	3-Wire 9 BIT data serial interface.	SDA SCL CS	1	1	1	4-Wire 8 BIT data serial interface	SDA SCL CS RS	I
IM3	IM2		IM0	Interface type	DB Pin in use																																	
0	0		0	DBI Tyb_ 8-bit interface	DB7-DB0																																	
0	1		0	DBI Tyb_ 16-bit interface	DB15-DB0																																	
0	0		1	DBI Tyb_ 9-bit interface	DB8-DB0																																	
0	1		1	DBI Tyb_ 18-bit interface	DB17-DB0																																	
1	0		1	3-Wire 9 BIT data serial interface.	SDA SCL CS																																	
1	1	1	4-Wire 8 BIT data serial interface	SDA SCL CS RS																																		
6	IM2	I																																				
7	IM0	I																																				
8	SDA	Serial input signal.The data is applied on the rising edge of the SCL signal. If not used, fix this pin at IOVCC or GND.	I																																			
9	VSYNC	Frame synchronizing signal for RGB interface operation. fix this pin at IOVCC or GND when not in use.	I																																			
10	HSYNC	Line synchronizing signal for RGB interface operation. fix this pin at IOVCC or GND when not in use	I																																			
11	DOTCLK	Dot clock signal for RGB interface operation Fix this pin at IOVCC or GND when not in use.	I																																			
12	ENABLE	Data enable signal for RGB interface operation. fix this pin at IOVCC or GND when not in use.	I																																			
13	RD	Serves as a read signal and MCU read data at the rising edge. fix this pin at IOVCC or GND when not in use.	I																																			
14	WR(SPI-RS)	(WR): Serves as a write signal and writes data at the rising edge. 4-line system (RS): Serves as command or parameter select. Fix to IOVCC or GND level when not in use.	I																																			
15	RS(SPI-SCL)	This pin is used to select "Data or Command" in the parallel interface. When RS = '1', data is selected. When RS = '0', command is selected. This pin is used serial interface clock in 3-wire 9-bit / 4-wire 8-bit serial data	I																																			

		interface. If not used, this pin should be connected to IOVCC or GND. RS_SCL1 is equal to RS(SCL).	
16	CS	Chip select input pin ("Low" enable). This pin can be permanently fixed "Low" in MPU interface mode only. CSX1 is equal to CSX.	I
17	RESET	This signal will reset the device and must be applied to properly initialize the chip. Signal is active low. RESX1 is equal to RESX.	I
18-35	DB17-DB0	18-bit parallel bi-directional data bus for MCU system and RGB interface mode Fix to GND level when not in use	I/O
36	NC	--	--
37	NC	--	--
38	LEDK	Cathode pin OF backlight	P
39	NC	--	--
40	LEDA	Anode pin of backlight	P
41	XR(NC)	No connected.	--
42	YU(NC)	No connected.	--
43	XL(NC)	No connected.	--
44	YD(NC)	No connected.	--
45	GND	Ground.	P

4. LCD Optical Characteristics

4.1 Optical specification

Item	Symbol	Condition	Min.	Typ.	Max.	Unit.	Note
Contrast Ratio	CR	Θ=0 Normal viewing angle	120	170	--		(1)(2)
Reflection Ratio (With Polarizer)	R		5	7	--	%	
Reflective Contrast Ratio	Cr		--	5	--	%	
Response time	Rising		T _{R+T_F}	--	30	50	msec
	Falling						
Color Gamut	S(%)		37	42	--	%	
Color Filter Chromaticity	White	W _X	-0.04	0.2917	+0.04		(1)(4) CA-310
		W _Y		0.3026			
	Red	R _X		0.5501			
		R _Y		0.3479			
	Green	G _X		0.3331			
		G _Y		0.5398			
	Blue	B _X		0.1581			
		B _Y		0.0841			
Viewing angle	Hor.	Θ _L	60	80	--		(1)(4)
		Θ _R	60	80	--		
	Ver.	Θ _U	60	80	--		
		Θ _D	60	80	--		
Option View Direction	Wide angle						

*The data comes from the LCD specification.

Measuring Condition

Measuring surrounding : dark rooms

Ambient temperature : 25±2°C

15min. warm-up time.

Measuring Equipment

FPM520 of Westar Display technologies, INC., which utilized SR-3 for Chromaticity and BM-5A for other optical characteristics.

Note (1): Definition of Viewing Angle :

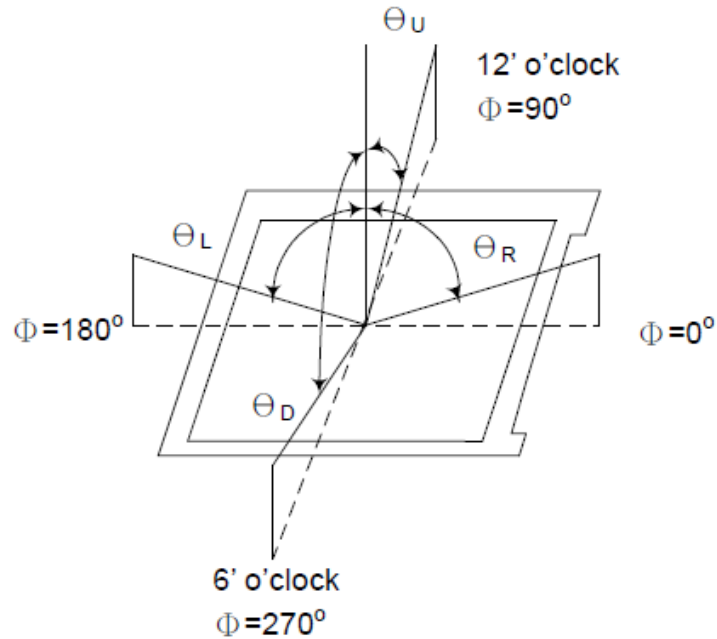

Note (2): Definition of Contrast Ratio(CR) :measured at the center point of panel

$$CR = \frac{\text{Luminance with all pixels white}}{\text{Luminance with all pixels black}}$$

Note (3): Response Time

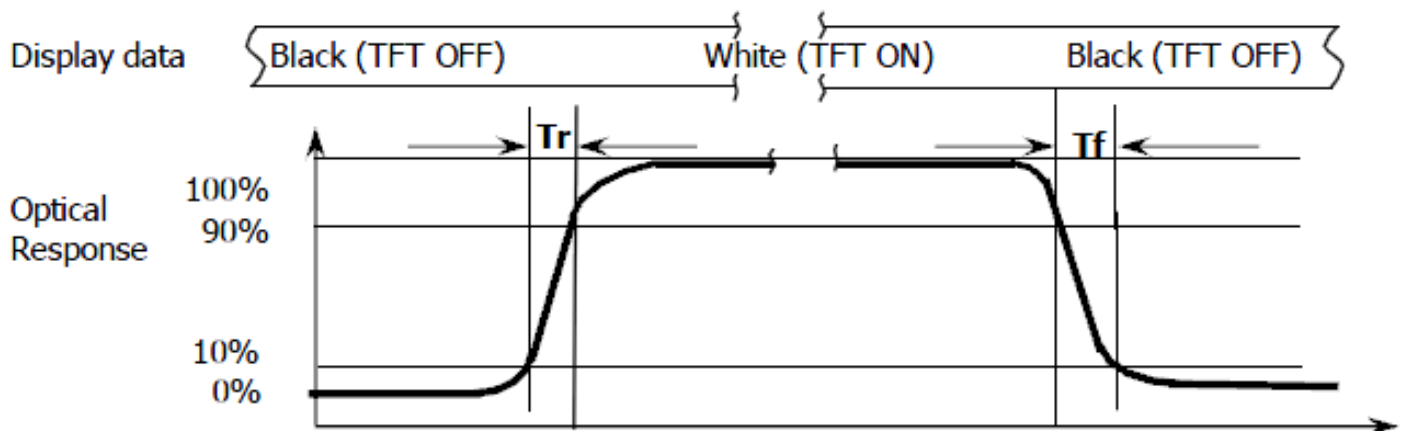

Note (4): Definition of optical measurement setup

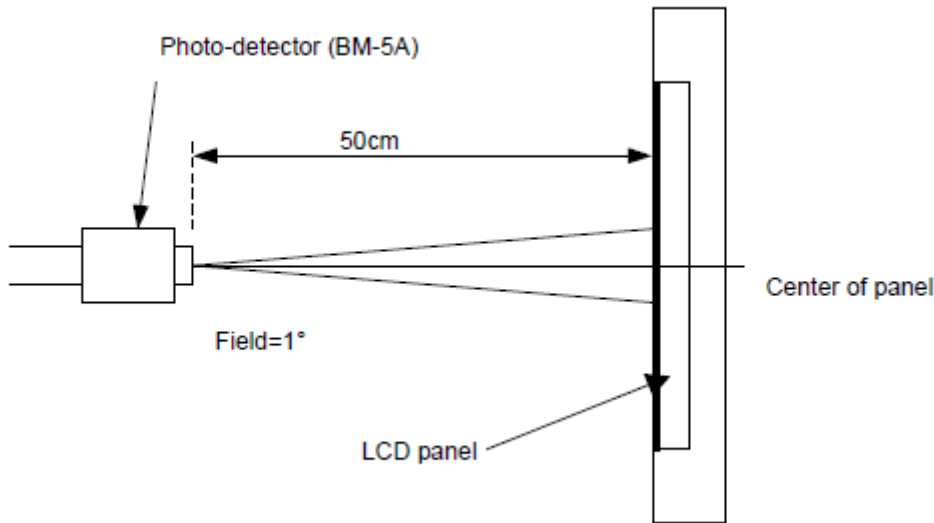

5. Electrical Characteristics

5.1 Absolute Maximum Rating

Characteristics	Symbol	Min.	Max.	Unit	Note
Digital Supply Voltage	V _{CI}	-0.3	4.2	V	Note1
Digital interface supply Voltage	IOV _{CC}	-0.3	3.3	V	Note1
Operating temperature	T _{OP}	-20	+70	°C	
Storage temperature	T _{ST}	-30	+80	°C	

NOTE1: If the absolute maximum rating of even is one of the above parameters is exceeded even momentarily, the quality of the product may be degraded. Absolute maximum ratings, therefore, specify the values exceeding which the product may be physically damaged. Be sure to use the product within the range of the absolute maximum ratings.

5.2 DC Electrical Characteristics

Characteristics	Symbol	Min.	Typ.	Max.	Unit	Note
Digital Supply Voltage	VCI	2.5	2.8/3.3	3.6	V	
Digital interface supply Voltage	IOVCC	1.65	1.8	3.3	V	
Normal mode Current	IDD	--	5	--	mA	
Level input voltage	V _{IH}	0.7*IOVCC	--	IOVCC	V	
	V _{IL}	GND	--	0.3*IOVCC	V	
Level output voltage	V _{OH}	0.8*IOVCC	--	IOVCC	V	
	V _{OL}	GND	--	0.2*IOVCC	V	

5.3 LED Backlight Characteristics

The back-light system is edge-lighting type with 8 chips LED

Item	Symbol	Min.	Typ.	Max.	Unit	Note
Forward Current	I _F	30	40	--	mA	
Forward Voltage	V _F	--	12	--	V	
LCM Luminance	LV	300	350	--	cd/m ²	I _F =40mA
LED life time	Hr	50000	--	--	Hour	Note1,2
Uniformity	Avg	80	--	--	%	Note3

Note1: LED life time (Hr) can be defined as the time in which it continues to operate under the condition:

T_a=25±3 °C, typical IL value indicated in the above table until the brightness becomes less than 50%.

Note 2: The "LED life time" is defined as the module brightness decrease to 50% original brightness at

T_a=25°C and I_L=40mA. The LED lifetime could be decreased if operating I_L is larger than 40mA. The constant current driving method is suggested.

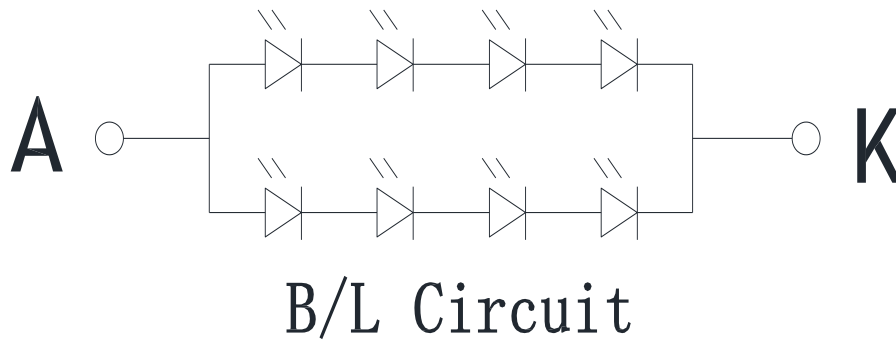

Note (3) Luminance Uniformity of these 9 points is defined as below:sss

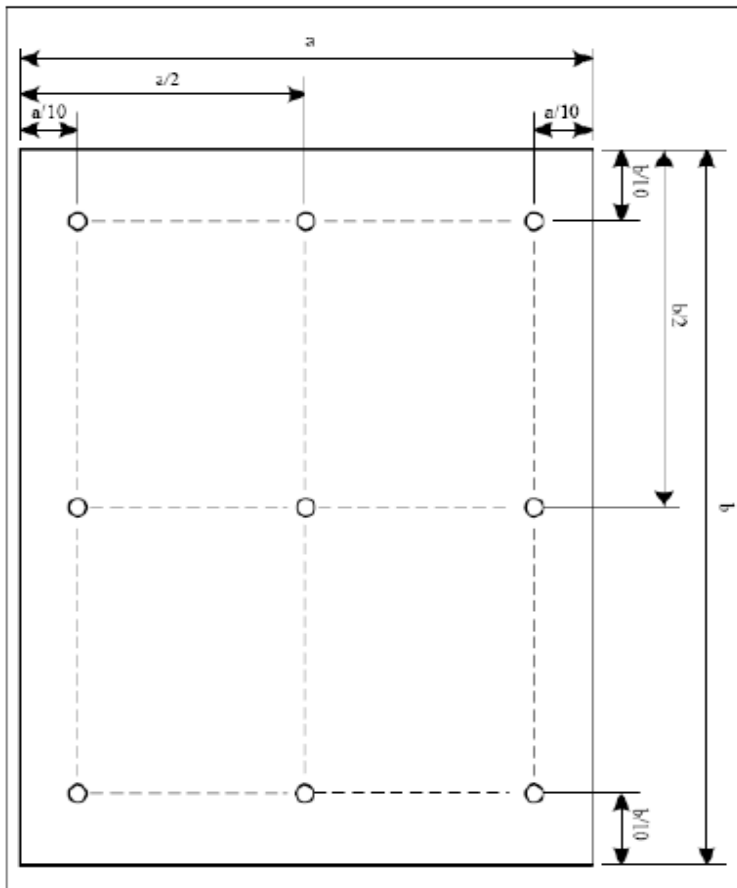

$$\text{Uniformity} = \frac{\text{minimum luminance in 9 points (1-9)}}{\text{maximum luminance in 9 points (1-9)}}$$

$$\text{Luminance} = \frac{\text{Total Luminance of 9 points}}{9}$$

6. AC Characteristics

6.1 Display Parallel 8/9/16/18-bit Interface Timing Characteristics (8080 system)

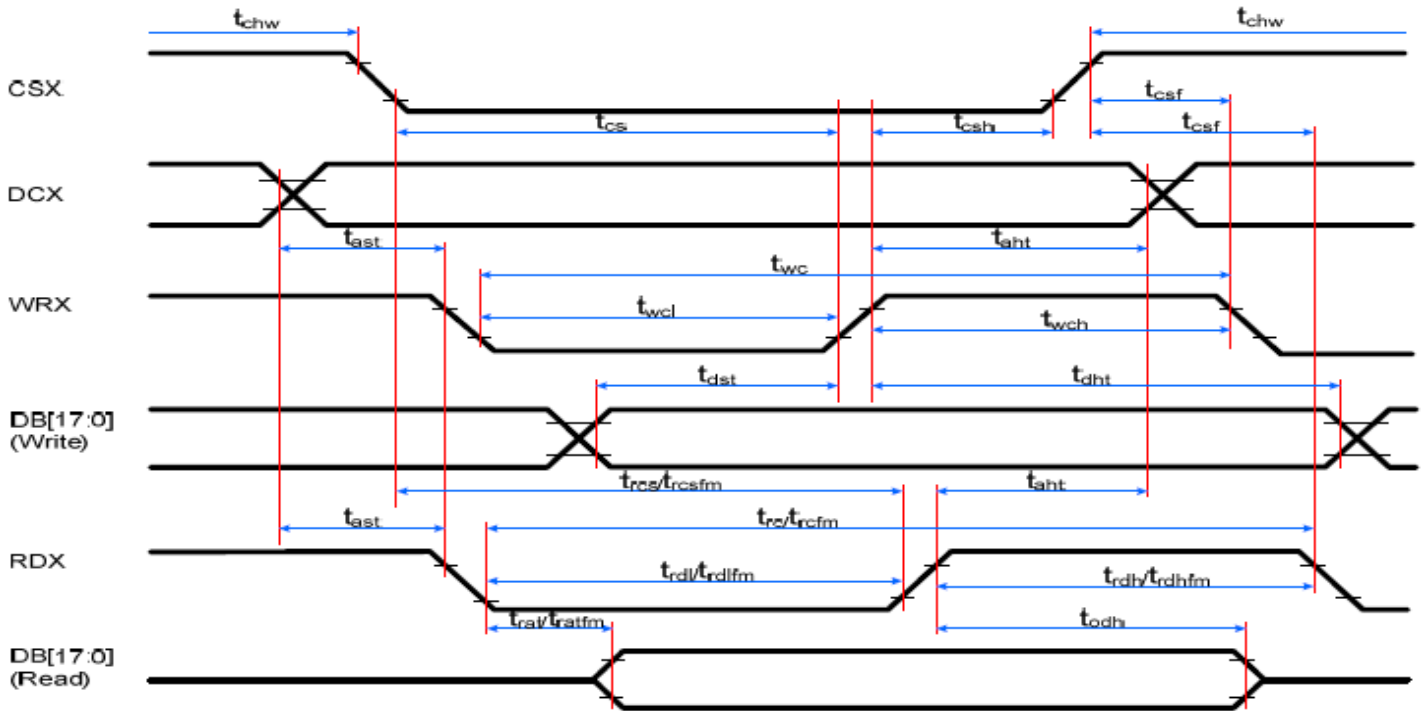

Signal	Symbol	Parameter	min	max	Unit	Description
DCX	tast	Address setup time	0	-	ns	
	taht	Address hold time (Write/Read)	10	-	ns	
CSX	tchw	CSX "H" pulse width	0	-	ns	
	tcs	Chip Select setup time (Write)	15	-	ns	
	trcs	Chip Select setup time (Read ID)	45	-	ns	
	trcsfm	Chip Select setup time (Read FM)	355	-	ns	
	tcsf	Chip Select Wait time (Write/Read)	10	-	ns	
WRX	twc	Write cycle	66	-	ns	
	twrh	Write Control pulse H duration	15	-	ns	
	twrl	Write Control pulse L duration	15	-	ns	
RDX (FM)	trcfm	Read Cycle (FM)	450	-	ns	
	trdhfm	Read Control H duration (FM)	90	-	ns	
	trdlfm	Read Control L duration (FM)	355	-	ns	
RDX (ID)	trc	Read cycle (ID)	160	-	ns	
	trdh	Read Control pulse H duration	90	-	ns	
	trdl	Read Control pulse L duration	45	-	ns	
D[17:0], D[17:10]&D[8:1], D[17:10], D[17:9]	tdst	Write data setup time	10	-	ns	For maximum CL=30pF For minimum CL=8pF
	tdht	Write data hold time	10	-	ns	
	trat	Read access time	-	40	ns	
	tratfm	Read access time	-	340	ns	
	trod	Read output disable time	20	80	ns	

Note: Ta = -30 to 70 °C, IOVCC=1.65V to 2.8V, VCI=2.6V to 3.3V, GND=0V.

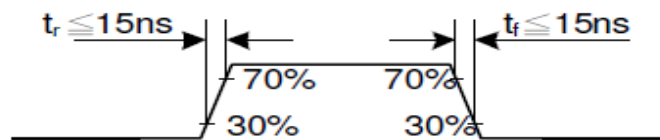

CSX timings :

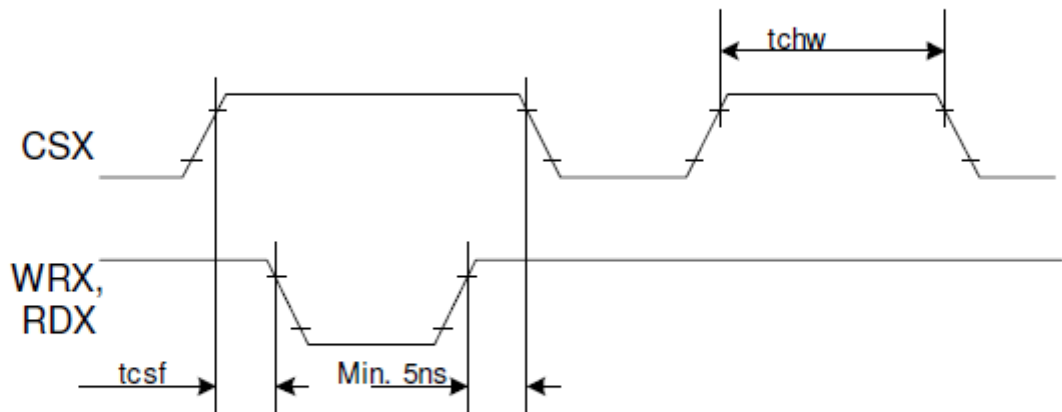

Note: Logic high and low levels are specified as 30% and 70% of IOVCC for Input signals.

Write to read or read to write timings:

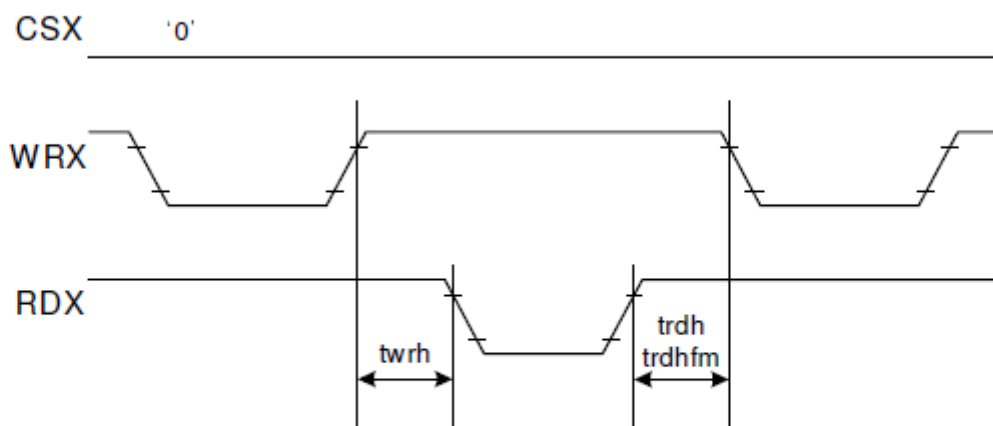

Note: Logic high and low levels are specified as 30% and 70% of IOVCC for Input signals.

6.3 Display Serial Interface Timing Characteristics (4-line SPI system)

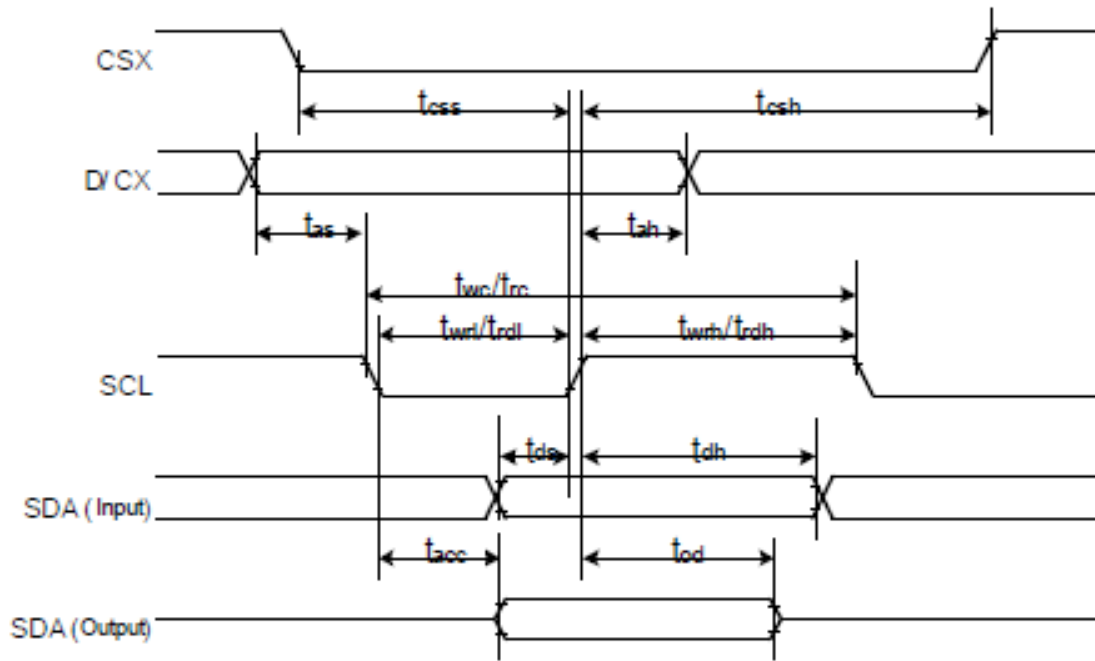

Signal	Symbol	Parameter	min	max	Unit	Description
CSX	t_{css}	Chip select time (Write)	30	-	ns	
	t_{csh}	Chip select hold time (write)	30	-	ns	
SCL	t_{wc}	Serial clock cycle (Write)	100	-	ns	
	t_{wrh}	SCL "H" pulse width (Write)	35	-	ns	
	t_{wrl}	SCL "L" pulse width (Write)	35	-	ns	
	t_{rc}	Serial clock cycle (Read)	150	-	ns	
	t_{rdh}	SCL "H" pulse width (Read)	60	-	ns	
	t_{rdl}	SCL "L" pulse width (Read)	60	-	ns	
D/CX	t_{as}	D/CX setup time	10	-		
	t_{ah}	D/CX hold time (Write / Read)	10	-		
SDA (Input)	t_{ds}	Data setup time (Write)	30	-	ns	
	t_{dh}	Data hold time (Write)	30	-	ns	
SDA (Output)	t_{acc}	Access time (Read)	-	50	ns	For maximum CL=30pF
	t_{od}	Output disable time (Read)	15	50	ns	For minimum CL=8pF

Note: $T_a = 25\text{ }^\circ\text{C}$, $IOVCC=1.65\text{V to }2.8\text{V}$, $VCI=2.6\text{V to }3.3\text{V}$, $AGND=GND=0\text{V}$

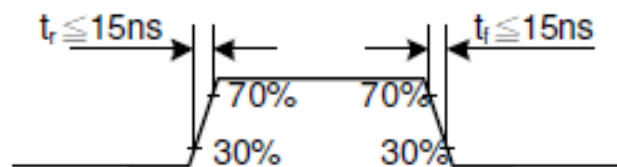

6.4 Parallel 16/18BIT RGB Interface Timing Characteristics

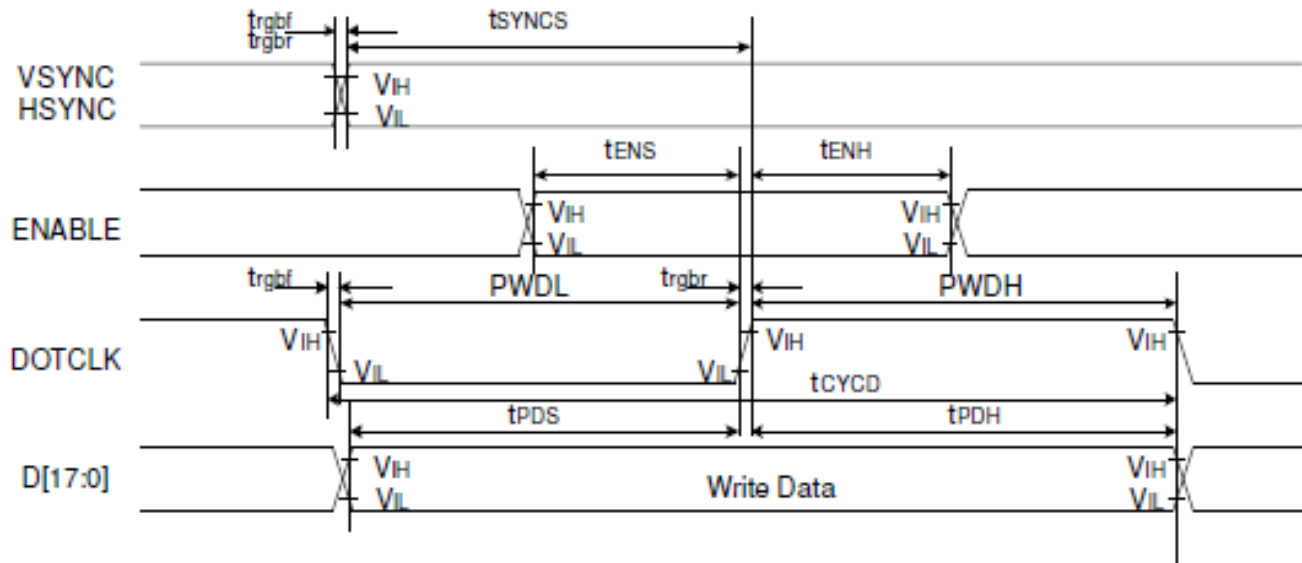

Signal	Symbol	Parameter	min	max	Unit	Description
VSYNC / HSYNC	t_{SYNCS}	VSYNC/HSYNC setup time	15	-	ns	18/16-bit bus RGB interface mode
	t_{SYNCH}	VSYNC/HSYNC hold time	15	-	ns	
DE	t_{ENS}	DE setup time	15	-	ns	
	t_{ENH}	DE hold time	15	-	ns	
D[17:0]	t_{POS}	Data setup time	15	-	ns	
	t_{PDH}	Data hold time	15	-	ns	
DOTCLK	$PWDH$	DOTCLK high-level period	33	-	ns	
	$PWDL$	DOTCLK low-level period	33	-	ns	
	t_{CYCD}	DOTCLK cycle time(18 bit)	100	-	ns	
	t_{rgb}, t_{grb}	DOTCLK,HSYNC,VSYNC rise/fall time	-	15	ns	
VSYNC / HSYNC	t_{SYNCS}	VSYNC/HSYNC setup time	15	-	ns	6-bit bus RGB interface mode
	t_{SYNCH}	VSYNC/HSYNC hold time	15	-	ns	
DE	t_{ENS}	DE setup time	15	-	ns	
	t_{ENH}	DE hold time	15	-	ns	
D[17:0]	t_{POS}	Data setup time	15	-	ns	
	t_{PDH}	Data hold time	15	-	ns	
DOTCLK	$PWDH$	DOTCLK high-level pulse period	25	-	ns	
	$PWDL$	DOTCLK low-level pulse period	25	-	ns	
	t_{CYCD}	DOTCLK cycle time	50	-	ns	
	t_{rgb}, t_{grb}	DOTCLK,HSYNC,VSYNC rise/fall time	-	15	ns	

Note: $T_a = -30$ to 70 °C, $IOVCC=1.65V$ to $2.8V$, $VCI=2.6V$ to $3.3V$, $AGND=GND=0V$

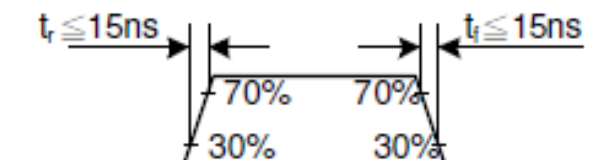

6.5 RGB Interface Timing

The timing chart of 18-/16-bit RGB interface mode is shown as below.

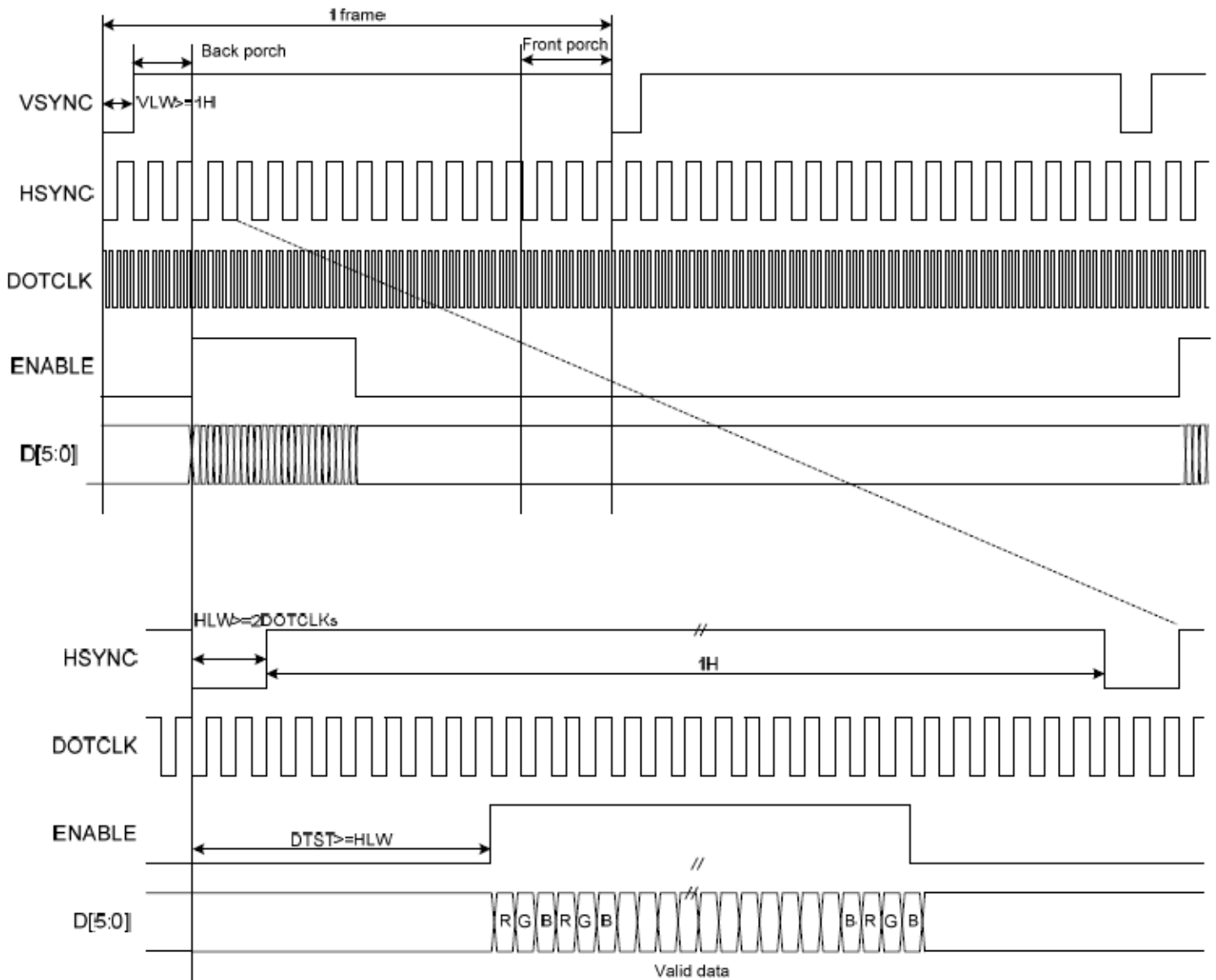

VLW : VSYNC Low Width HLW : HSYNC Low Width DTST : Data Transfer Startup Time

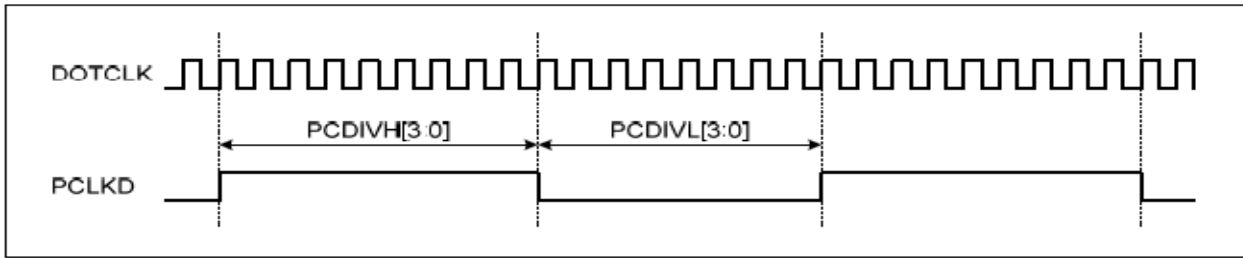

Note 1: The DE signal is not needed when RGB interface SYNC mode is selected.

Note 2: VSPL='0', HSPL='0', DPL='0' and EPL='1' of "Interface Mode Control (B0h)" command.

Note 3: In 6-bit RGB interface mode, each dot of one pixel (R, G and B) is transferred in synchronization with DOTCLK.

Note 4: In 6-bit RGB interface mode, set the cycles of VSYNC, HSYNC and DE to 3 multiples of DOTCLK.

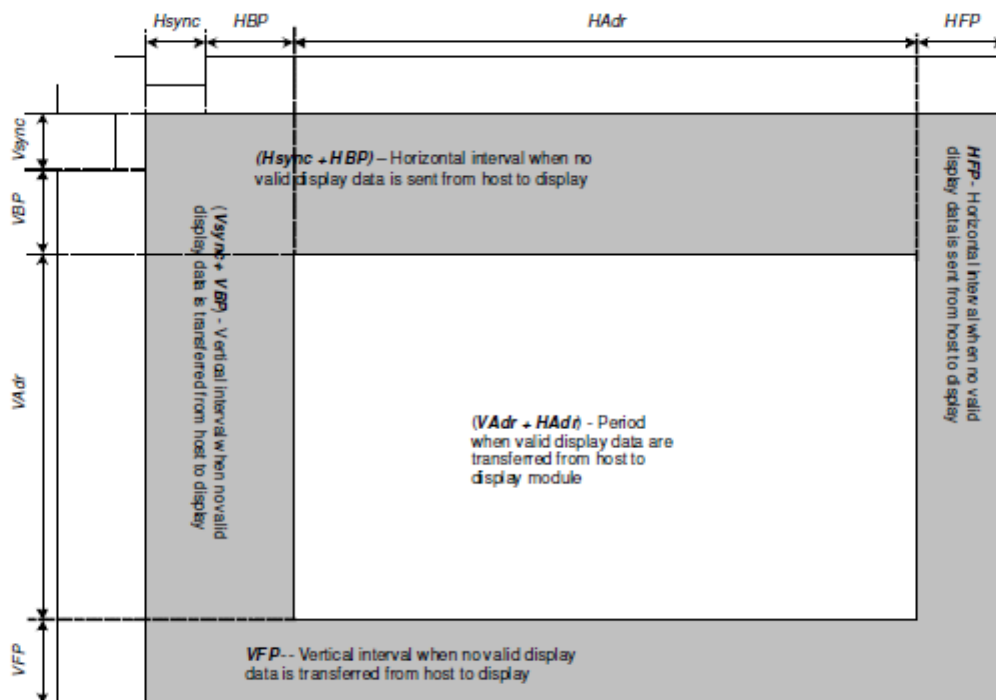

Parameters	Symbols	Condition	Min.	Typ.	Max.	Units
Horizontal Synchronization	Hsync		2	10	16	DOTCLK
Horizontal Back Porch	HBP		2	20	24	DOTCLK
Horizontal Back Porch(By pass mode)*	HBP(BP)		58	68	200	DOTCLK
Horizontal Address	HAdr		-	320	-	DOTCLK
Horizontal Front Porch	HFP		2	10	16	DOTCLK
Vertical Synchronization	Vsync		1	2	4	Line
Vertical Back Porch	VBP		1	2	-	Line
Vertical Address	VAdr		-	240	-	Line
Vertical Front Porch	VFP		3	4	-	Line

6.6 Reset Timing Characteristics

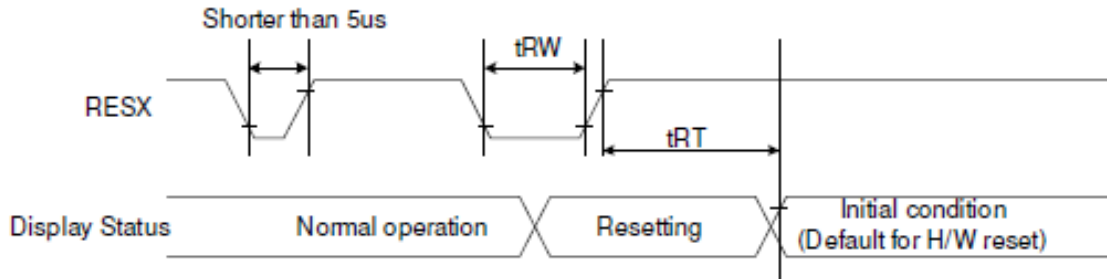

Signal	Symbol	Parameter	Min	Max	Unit
RESX	t_{RW}	Reset pulse duration	10		μ S
	t_{RT}	Reset cancel		5 (note 1,5)	mS
				120 (note 1,6,7)	mS

Note 1: The reset cancel includes also required time for loading ID bytes, VCOM setting and other settings from NV memory to registers. This loading is done every time when there is HW reset cancel time (t_{RT}) within 5 ms after a rising edge of RESX.

Note 2: Spike due to an electrostatic discharge on RESX line does not cause irregular system reset according to the table below: -

RESX Pulse	Action
Shorter than 5 μ s	Reset Rejected
Longer than 10 μ s	Reset
Between 5 μ s and 10 μ s	Reset starts

Note 3: During the Resetting period, the display will be blanked (The display is entering blanking sequence, which maximum time is 120 ms, when Reset Starts in Sleep Out –mode. The display remains the blank state in Sleep In -mode.) And then return to Default condition for Hardware Reset.

Note 4: Spike Rejection also applies during a valid reset pulse as shown below:

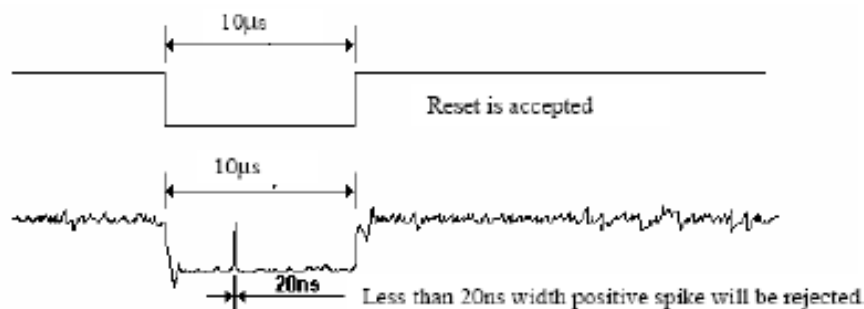

Note 5: When Reset applied during Sleep In Mode.

Note 6: When Reset applied during Sleep Out Mode.

Note 7: It is necessary to wait 5msec after releasing RESX before sending commands. Also Sleep Out command cannot be sent for 120msec.

7. LCD Module Out-Going Quality Level

7.1 VISUAL & FUNCTION INSPECTION STANDARD

7.1.1 Inspection conditions

Inspection performed under the following conditions is recommended.

Temperature : 25±5°C

Humidity : 65%±10%RH

Viewing Angle : Normal viewing Angle.

Illumination: Single fluorescent lamp (300 to 700Lux)

Viewing distance:30-50cm

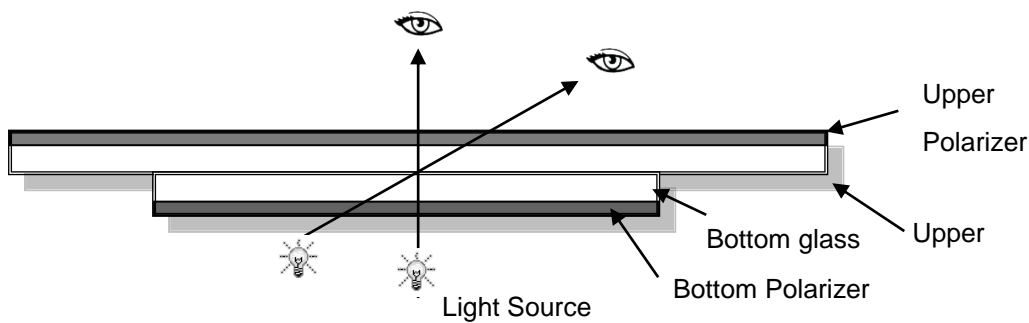

7.1.2 Definition

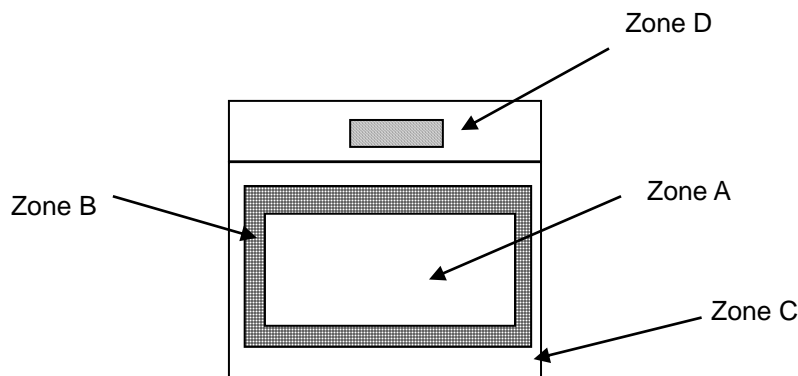

Zone A : Effective Viewing Area(Character or Digit can be seen)

Zone B : Viewing Area except Zone A

Zone C : Outside (Zone A+Zone B) which can not be seen after assembly by customer .)

Zone D : IC Bonding Area

Note:As a general rule ,visual defects in Zone C can be ignored when it doesn't effect product function or appearance after assembly by customer

7.1.3 Sampling Plan

According to GB/T 2828-2012 ; , normal inspection, Class II

AQL:

Major defect	Minor defect
0.65	1.5

LCD: Liquid Crystal Display , LCM: Liquid Crystal Module,

No	Items to be inspected	Criteria	Classification of defects
1	Functional defects	1) No display, Open or miss line 2) Display abnormally, Short 3) Backlight no lighting, abnormal lighting. etc...	Major
2	Missing	Missing components and etc...	
3	Outline dimension	Overall outline dimension beyond the drawing is not allowed, deformation and etc...	
4	Color tone	Color unevenness, refer to limited sample	Minor
5	Spot/Line defect	Light dot, Dim spot, (Note1) Polarizer Air Bubble, Polarizer accidented spot and etc.	
6	Soldering appearance	Good soldering , Peeling off is not allowed and etc.	
7	LCD/Polarizer	Black/White spot/line, scratch, crack, etc.	

Note1: a) Light dot: Dots appear bright and unchanged in size in which LCD panel is displaying under black pattern.

b) Dim dot: Dots appear dark and unchanged in size in which LCD panel is displaying under pure red, green, blue picture.

7.1.4 Criteria (Visual)

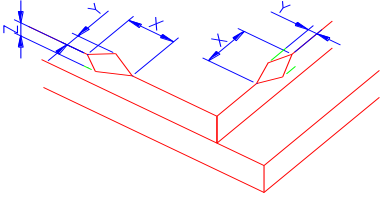
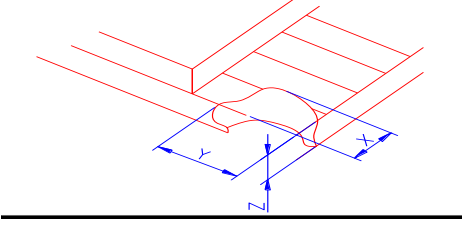
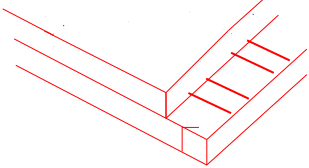
Number	Items	Criteria(mm)						
1.0 LCD Crack/Broken NOTE: X: Length Y: Width Z: Height L: Length of ITO, T: Height of LCD	(1) The edge of LCD broken	 <table border="1" data-bbox="756 613 1455 761"> <thead> <tr> <th>X</th> <th>Y</th> <th>Z</th> </tr> </thead> <tbody> <tr> <td>≤3.0mm</td> <td><Inner border line of the seal</td> <td>≤T</td> </tr> </tbody> </table>	X	Y	Z	≤3.0mm	<Inner border line of the seal	≤T
	X	Y	Z					
	≤3.0mm	<Inner border line of the seal	≤T					
(2) LCD corner broken	 <table border="1" data-bbox="836 1070 1375 1169"> <thead> <tr> <th>X</th> <th>Y</th> <th>Z</th> </tr> </thead> <tbody> <tr> <td>≤3.0mm</td> <td>≤L</td> <td>≤T</td> </tr> </tbody> </table>	X	Y	Z	≤3.0mm	≤L	≤T	
X	Y	Z						
≤3.0mm	≤L	≤T						
(3) LCD crack	 <p style="text-align: center;">Crack Not allowed</p>							

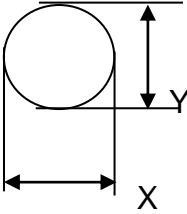
2.0	Spot defect	<p>① light dot (black/white spot , pinhole, stain, etc.)</p> <table border="1" style="width: 100%; border-collapse: collapse;"> <thead> <tr> <th rowspan="2" style="text-align: center;">Zone Size (mm)</th> <th colspan="3" style="text-align: center;">Acceptable Qty</th> </tr> <tr> <th style="text-align: center;">A</th> <th style="text-align: center;">B</th> <th style="text-align: center;">C</th> </tr> </thead> <tbody> <tr> <td style="text-align: center;">$\Phi \leq 0.15$</td> <td colspan="3" style="text-align: center;">Ignore</td> </tr> <tr> <td style="text-align: center;">$0.15 < \Phi \leq 0.25$</td> <td colspan="3" style="text-align: center;">3(distance ≥ 6mm)</td> </tr> <tr> <td style="text-align: center;">$0.25 < \Phi \leq 0.4$</td> <td colspan="3" style="text-align: center;">2(distance ≥ 6mm)</td> </tr> <tr> <td style="text-align: center;">$\Phi > 0.4$</td> <td colspan="3" style="text-align: center;">0</td> </tr> </tbody> </table> <p>② Dim spot (light leakage, dent, dark spot, etc)</p> <table border="1" style="width: 100%; border-collapse: collapse;"> <thead> <tr> <th rowspan="2" style="text-align: center;">Zone Size (mm)</th> <th colspan="3" style="text-align: center;">Acceptable Qty</th> </tr> <tr> <th style="text-align: center;">A</th> <th style="text-align: center;">B</th> <th style="text-align: center;">C</th> </tr> </thead> <tbody> <tr> <td style="text-align: center;">$\Phi \leq 0.15$</td> <td colspan="3" style="text-align: center;">Ignore</td> </tr> <tr> <td style="text-align: center;">$0.15 < \Phi \leq 0.25$</td> <td colspan="3" style="text-align: center;">3(distance ≥ 6mm)</td> </tr> <tr> <td style="text-align: center;">$0.25 < \Phi \leq 0.4$</td> <td colspan="3" style="text-align: center;">2(distance ≥ 6mm)</td> </tr> <tr> <td style="text-align: center;">$\Phi > 0.4$</td> <td colspan="3" style="text-align: center;">0</td> </tr> </tbody> </table> <p>③ Polarizer accidented spot</p> <table border="1" style="width: 100%; border-collapse: collapse;"> <thead> <tr> <th rowspan="2" style="text-align: center;">Zone Size (mm)</th> <th colspan="3" style="text-align: center;">Acceptable Qty</th> </tr> <tr> <th style="text-align: center;">A</th> <th style="text-align: center;">B</th> <th style="text-align: center;">C</th> </tr> </thead> <tbody> <tr> <td style="text-align: center;">$\Phi \leq 0.2$</td> <td colspan="2" style="text-align: center;">Ignore</td> <td rowspan="3" style="text-align: center;">Ignore</td> </tr> <tr> <td style="text-align: center;">$0.2 < \Phi \leq 0.5$</td> <td colspan="2" style="text-align: center;">2(distance ≥ 6mm)</td> </tr> <tr> <td style="text-align: center;">$\Phi > 0.5$</td> <td colspan="2" style="text-align: center;">0</td> </tr> </tbody> </table> <p>④ Polarizer Bubble</p> <table border="1" style="width: 100%; border-collapse: collapse;"> <thead> <tr> <th rowspan="2" style="text-align: center;">Zone Size (mm)</th> <th colspan="3" style="text-align: center;">Acceptable Qty</th> </tr> <tr> <th style="text-align: center;">A</th> <th style="text-align: center;">B</th> <th style="text-align: center;">C</th> </tr> </thead> <tbody> <tr> <td style="text-align: center;">$\Phi \leq 0.2$</td> <td colspan="2" style="text-align: center;">Ignore</td> <td rowspan="3" style="text-align: center;">Ignore</td> </tr> <tr> <td style="text-align: center;">$0.2 < \Phi \leq 0.4$</td> <td colspan="2" style="text-align: center;">3(distance ≥ 6mm)</td> </tr> <tr> <td style="text-align: center;">$\Phi > 0.4$</td> <td colspan="2" style="text-align: center;">0</td> </tr> </tbody> </table>	Zone Size (mm)	Acceptable Qty			A	B	C	$\Phi \leq 0.15$	Ignore			$0.15 < \Phi \leq 0.25$	3(distance ≥ 6 mm)			$0.25 < \Phi \leq 0.4$	2(distance ≥ 6 mm)			$\Phi > 0.4$	0			Zone Size (mm)	Acceptable Qty			A	B	C	$\Phi \leq 0.15$	Ignore			$0.15 < \Phi \leq 0.25$	3(distance ≥ 6 mm)			$0.25 < \Phi \leq 0.4$	2(distance ≥ 6 mm)			$\Phi > 0.4$	0			Zone Size (mm)	Acceptable Qty			A	B	C	$\Phi \leq 0.2$	Ignore		Ignore	$0.2 < \Phi \leq 0.5$	2(distance ≥ 6 mm)		$\Phi > 0.5$	0		Zone Size (mm)	Acceptable Qty			A	B	C	$\Phi \leq 0.2$	Ignore		Ignore	$0.2 < \Phi \leq 0.4$	3(distance ≥ 6 mm)		$\Phi > 0.4$	0	
	Zone Size (mm)			Acceptable Qty																																																																														
			A	B	C																																																																													
	$\Phi \leq 0.15$		Ignore																																																																															
$0.15 < \Phi \leq 0.25$	3(distance ≥ 6 mm)																																																																																	
$0.25 < \Phi \leq 0.4$	2(distance ≥ 6 mm)																																																																																	
$\Phi > 0.4$	0																																																																																	
Zone Size (mm)	Acceptable Qty																																																																																	
	A	B	C																																																																															
$\Phi \leq 0.15$	Ignore																																																																																	
$0.15 < \Phi \leq 0.25$	3(distance ≥ 6 mm)																																																																																	
$0.25 < \Phi \leq 0.4$	2(distance ≥ 6 mm)																																																																																	
$\Phi > 0.4$	0																																																																																	
Zone Size (mm)	Acceptable Qty																																																																																	
	A	B	C																																																																															
$\Phi \leq 0.2$	Ignore		Ignore																																																																															
$0.2 < \Phi \leq 0.5$	2(distance ≥ 6 mm)																																																																																	
$\Phi > 0.5$	0																																																																																	
Zone Size (mm)	Acceptable Qty																																																																																	
	A	B	C																																																																															
$\Phi \leq 0.2$	Ignore		Ignore																																																																															
$0.2 < \Phi \leq 0.4$	3(distance ≥ 6 mm)																																																																																	
$\Phi > 0.4$	0																																																																																	
																																																																																		
	$\Phi = (X+Y)/2$																																																																																	

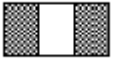
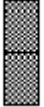
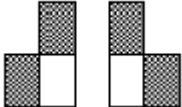
3.0	LCD Pixel defect	<p>Pixel bad points</p> <table border="1"> <thead> <tr> <th data-bbox="539 253 730 304">Item</th> <th data-bbox="730 253 1241 304">Zone A</th> <th data-bbox="1241 253 1497 304">Acceptable Qty</th> </tr> </thead> <tbody> <tr> <td data-bbox="539 304 730 465" rowspan="3">Bright dot</td> <td data-bbox="730 304 1241 360">Random</td> <td data-bbox="1241 304 1497 360">N≤2</td> </tr> <tr> <td data-bbox="730 360 1241 416">2 dots adjacent</td> <td data-bbox="1241 360 1497 416">N≤0</td> </tr> <tr> <td data-bbox="730 416 1241 465">3 dots adjacent</td> <td data-bbox="1241 416 1497 465">N≤0</td> </tr> <tr> <td data-bbox="539 465 730 633" rowspan="3">Dark dot</td> <td data-bbox="730 465 1241 521">Random</td> <td data-bbox="1241 465 1497 521">N≤2</td> </tr> <tr> <td data-bbox="730 521 1241 577">2 dots adjacent</td> <td data-bbox="1241 521 1497 577">N≤0</td> </tr> <tr> <td data-bbox="730 577 1241 633">3 dots adjacent</td> <td data-bbox="1241 577 1497 633">N≤0</td> </tr> <tr> <td data-bbox="539 633 730 943">Distance</td> <td data-bbox="730 633 1241 943"> 1. Minimum Distance Between Bright dots. 2. Minimum Distance Between dark dots 3. Minimum Distance Between dark and bright dot. </td> <td data-bbox="1241 633 1497 943">5mm</td> </tr> <tr> <td colspan="2" data-bbox="539 943 1241 999">Total bright and dark dot</td> <td data-bbox="1241 943 1497 999">N≤4</td> </tr> </tbody> </table> <p>Note:</p> <p>A) Bright dot: Dots appear bright and unchanged in size in which LCD panel is displaying under black pattern.</p> <p>B) Dark dot: Dots appear dark and unchanged in size in which LCD panel is displaying under pure red, green, blue picture.</p> <p>C) 2 dot adjacent = 1 pair = 2 dots</p> <p>Picture:</p> <div style="display: flex; justify-content: space-around; align-items: flex-start;"> <div style="text-align: center;">  <p>2 dot adjacent</p> </div> <div style="text-align: center;">  <p>2 dot adjacent</p> </div> <div style="text-align: center;">  <p>2 dot adjacent (vertical)</p> </div> <div style="text-align: center;">  <p>2 dot adjacent (slant)</p> </div> </div>	Item	Zone A	Acceptable Qty	Bright dot	Random	N≤2	2 dots adjacent	N≤0	3 dots adjacent	N≤0	Dark dot	Random	N≤2	2 dots adjacent	N≤0	3 dots adjacent	N≤0	Distance	1. Minimum Distance Between Bright dots. 2. Minimum Distance Between dark dots 3. Minimum Distance Between dark and bright dot.	5mm	Total bright and dark dot		N≤4
Item	Zone A	Acceptable Qty																							
Bright dot	Random	N≤2																							
	2 dots adjacent	N≤0																							
	3 dots adjacent	N≤0																							
Dark dot	Random	N≤2																							
	2 dots adjacent	N≤0																							
	3 dots adjacent	N≤0																							
Distance	1. Minimum Distance Between Bright dots. 2. Minimum Distance Between dark dots 3. Minimum Distance Between dark and bright dot.	5mm																							
Total bright and dark dot		N≤4																							

4.0	Line defect (LCD /Polarizer backlight black/white line, scratch, stain)  W: width, L : length N : Count	<table border="1"> <thead> <tr> <th rowspan="2">Width(mm)</th> <th rowspan="2">Length(m m)</th> <th colspan="3">Acceptable Qty</th> </tr> <tr> <th>A</th> <th>B</th> <th>C</th> </tr> </thead> <tbody> <tr> <td>$\Phi \leq 0.03$</td> <td>Ignore</td> <td colspan="2">Ignore</td> <td rowspan="3">Ignore</td> </tr> <tr> <td>$0.03 < W \leq 0.04$</td> <td>$L \leq 3.0$</td> <td colspan="2">$N \leq 2$</td> </tr> <tr> <td>$0.04 < W \leq 0.05$</td> <td>$L \leq 2.0$</td> <td colspan="2">$N \leq 1$</td> </tr> <tr> <td>$W > 0.05$</td> <td colspan="4">Define as spot defect</td> </tr> </tbody> </table>	Width(mm)	Length(m m)	Acceptable Qty			A	B	C	$\Phi \leq 0.03$	Ignore	Ignore		Ignore	$0.03 < W \leq 0.04$	$L \leq 3.0$	$N \leq 2$		$0.04 < W \leq 0.05$	$L \leq 2.0$	$N \leq 1$		$W > 0.05$	Define as spot defect			
		Width(mm)			Length(m m)	Acceptable Qty																						
			A	B		C																						
		$\Phi \leq 0.03$	Ignore	Ignore		Ignore																						
		$0.03 < W \leq 0.04$	$L \leq 3.0$	$N \leq 2$																								
$0.04 < W \leq 0.05$	$L \leq 2.0$	$N \leq 1$																										
$W > 0.05$	Define as spot defect																											
5.0	Electronic Components SMT.	Not allow missing parts, solderless connection, cold solder joint, mismatch, The positive and negative polarity opposite																										
6.0	Display color & Brightness.	1. Color: Measuring the color coordinates, The measurement standard according to the datasheet or samples. 2. Brightness: Measuring the brightness of White screen, The measurement standard according to the datasheet or Samples.																										
7.0	LCD Mura/Waving/ Hot spot	Not visible through 5% ND filter in 50% gray or judge by limit sample if necessary.																										

Criteria (functional items)

Number	Items	Criteria (mm)
1	No display	Not allowed
2	Missing segment	Not allowed
3	Short	Not allowed
4	Backlight no lighting	Not allowed

8. Reliability Test Result

Remark:

Item	Condition	Inspection after test
High Temperature Operating	70°C,96H	Inspection after 2~4hours storage at room temperature, the sample shall be free from defects: 1.Air bubble in the LCD; 2.Non-display; 3.Missing segments/line; 4.Glass crack; 5.Current IDD is twice higher than initial value.
Low Temperature Operating	-20°C, 96HR	
High Temperature Storage	80°C, 96HR	
Low Temperature Storage	-30°C, 96HR	
High Temperature & High Humidity Operating	+60°C, 90% RH ,96 hours.	
Thermal Shock (Non-operation)	-10°C,30 min ↔ +60°C,30 min, Change time:5min 20CYC.	
ESD test	C=150pF, R=330,5points/panel Air:±8KV, 5times; Contact:±6KV, 5 times; (Environment: 15°C~35°C, 30%~60%).	
Vibration (Non-operation)	Frequency range:10~55Hz, Stroke:1.5mm Sweep:10Hz~55Hz~10Hz 2 hours for each direction of X.Y.Z. (6 hours for total) (Package condition).	
Box Drop Test	1 Corner 3 Edges 6 faces,80cm(MEDIUM BOX)	

- 1.The test samples should be applied to only one test item.
- 2.Sample size for each test item is 5~10pcs.
- 3.For Damp Proof Test, Pure water(Resistance > 10MΩ) should be used.
- 4.In case of malfunction defect caused by ESD damage, if it would be recovered to normal state after resetting, it would be judged as a good part.
- 5.Failure Judgment Criterion: Basic Specification, Electrical Characteristic, Mechanical Characteristic, Optical Characteristic.
6. The color fading mura of polarizing filter should not care.

9. Cautions and Handling Precautions

9.1 Handling and Operating the Module

(1) When the module is assembled, it should be attached to the system firmly.

Do not warp or twist the module during assembly work.

(2) Protect the module from physical shock or any force. In addition to damage, this may cause improper operation or damage to the module and back-light unit.

(3) Note that polarizer is very fragile and could be easily damaged. Do not press or scratch the surface.

(4) Do not allow drops of water or chemicals to remain on the display surface.

If you have the droplets for a long time, staining and discoloration may occur.

(5) If the surface of the polarizer is dirty, clean it using some absorbent cotton or soft cloth.

(6) The desirable cleaners are water, IPA (Isopropyl Alcohol) or Hexane.

Do not use ketene type materials (ex. Acetone), Ethyl alcohol, Toluene, Ethyl acid or Methyl chloride. It might permanent damage to the polarizer due to chemical reaction.

(7) If the liquid crystal material leaks from the panel, it should be kept away from the eyes or mouth. In case of contact with hands, legs, or clothes, it must be washed away thoroughly with soap.

(8) Protect the module from static; it may cause damage to the CMOS ICs.

(9) Use finger-stalls with soft gloves in order to keep display clean during the incoming inspection and assembly process.

(10) Do not disassemble the module.

(11) Protection film for polarizer on the module shall be slowly peeled off just before use so that the electrostatic charge can be minimized.

(12) Pins of I/F connector shall not be touched directly with bare hands.

(13) Do not connect, disconnect the module in the "Power ON" condition.

9.2 Storage and Transportation.

(1) Do not leave the panel in high temperature, and high humidity for a long time.

It is highly recommended to store the module with temperature from 0 to 35 °C and relative humidity of less than 70%

(2) Do not store the TFT-LCD module in direct sunlight.

(3) The module shall be stored in a dark place. When storing the modules for a long time, be sure to adopt effective measures for protecting the modules from strong ultraviolet radiation, sunlight, or fluorescent light.

(4) It is recommended that the modules should be stored under a condition where no condensation is allowed. Formation of dewdrops may cause an abnormal operation or a failure of the module.

In particular, the greatest possible care should be taken to prevent any module from being operated where condensation has occurred inside.

(5) This panel has its circuitry FPC on the bottom side and should be handled carefully in order not to be stressed.