

## Bi-directional ESD Protection Diode

### DESCRIPTIONS

The TESDA6V0B20P1Q0 is Bidirectional ESD rated clamping cell to protect power interfaces, or one control line, or one low speed data line in an electronic system. It has been specifically designed to protect sensitive electronic components which are connected to power and control lines from over-voltage damage by Electrostatic Discharging (ESD), and Lightning.

ESD protection device in an ultra-small DFN0603 Surface-Mounted Device (SMD) plastic package designed to protect two automotive In-vehicle network bus lines from the damage caused by Electrostatics discharge (ESD) and other transients.

The TESDA6V0B20P1Q0 may be used to provide ESD protection up to  $\pm 30\text{kV}$  (contact and air discharge) according to IEC61000-4-2, and withstand peak pulse current up to 5A (8/20 $\mu\text{s}$ ) according to IEC61000-4-5.



### FEATURES

- AEC-Q101 qualified
- ESD protect for 1 line with bidirectional
- Provide ESD protection to
  - IEC 61000-4-2 (ESD)  $\pm 30\text{kV}$  (air),  $\pm 30\text{kV}$  (contact)
  - IEC 61000-4-4 (EFT) 40A (5/50ns)
  - IEC 61000-4-5 (Lightning) 5A (8/20us)
- Suitable for 5V and below, operating voltage applications
- Ultra small packages save board space
- Protect one I/O line or one power line
- Moisture sensitivity level: level 1, per J-STD-020
- RoHS Compliant
- Halogen-Free

### APPLICATION

- Portable medical devices
- Smart phones
- PDAs

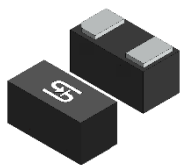

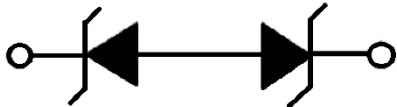
PACKAGE: DFN0603-2L	PIN CONFIGURATION	CIRCUIT DIAGRAM
		

<b>ABSOLUTE MAXIMUM RATINGS</b> ( $T_A = 25^\circ\text{C}$ unless otherwise noted)			
PARAMETER	SYMBOL	VALUE	UNIT
Typical peak pulse power ( $t_p = 8/20\mu\text{s}$ )	$P_{PK}$	56	W
Peak pulse current ( $t_p = 8/20\mu\text{s}$ )	$I_{PP}$	5	A
ESD according to IEC61000-4-2 air discharge	$V_{ESD}$	$\pm 30$	kV
ESD according to IEC61000-4-2 contact discharge		$\pm 30$	kV
Operating junction temperature range	$T_J$	-55 to +150	$^\circ\text{C}$
Storage temperature range	$T_{STG}$	-55 to +150	$^\circ\text{C}$

<b>ELECTRICAL SPECIFICATIONS</b> ( $T_A = 25^\circ\text{C}$ unless otherwise noted)						
PARAMETER	CONDITIONS	SYMBOL	MIN	TYP	MAX	UNIT
Reverse working voltage		$V_{RWM}$	-	-	6	V
Reverse breakdown voltage	$I_R = 1\text{mA}$ , $T_J = 25^\circ\text{C}$	$V_{BR}$	-	8.2	-	V
Reverse leakage current	$V_{RWM} = 6\text{V}$ , $T_J = 25^\circ\text{C}$	$I_R$	-	15.3	500	nA
Clamping voltage <sup>(1)</sup>	$I_{PP} = 1\text{A}$ , $t_p = 8/20\mu\text{s}$	$V_C$	-	9.0	-	V
	$I_{PP} = 2\text{A}$ , $t_p = 8/20\mu\text{s}$		-	9.5	-	V
	$I_{PP} = 5\text{A}$ , $t_p = 8/20\mu\text{s}$		-	11.2	-	V
Clamping voltage <sup>(2)</sup>	$I_{TLP} = 4\text{A}$ , $t_p = 100\text{ns}$	$V_{CL}$	-	10.3	-	V
	$I_{TLP} = 16\text{A}$ , $t_p = 100\text{ns}$		-	15.6	-	V
Junction capacitance	1MHz, $V_R = 0\text{V}$	$C_J$	-	16.5	20	pF
	1MHz, $V_R = 2.5\text{V}$		-	12.4	-	pF
Dynamic resistance <sup>(2)</sup>		$R_{DYN}$	-	0.44	-	$\Omega$

**Notes:**

1. Non-repetitive current pulse, according to IEC61000-4-5.
2. TLP parameter:  $Z_0 = 50\ \Omega$ ,  $t_p = 100\text{ns}$ ,  $t_r = 2\text{ns}$ , averaging window from 60ns to 80ns.  $R_{DYN}$  is calculated from 4A to 16A.

<b>ORDERING INFORMATION</b>		
ORDERING CODE	PACKAGE	PACKING
TESDA6V0B20P1Q0 M6G	DFN0603-2L	15,000 / 7" Reel

**CHARACTERISTICS CURVES**

( $T_A = 25^\circ\text{C}$  unless otherwise noted)

**Fig.1 Peak Pulse Power vs. Junction Temperature**

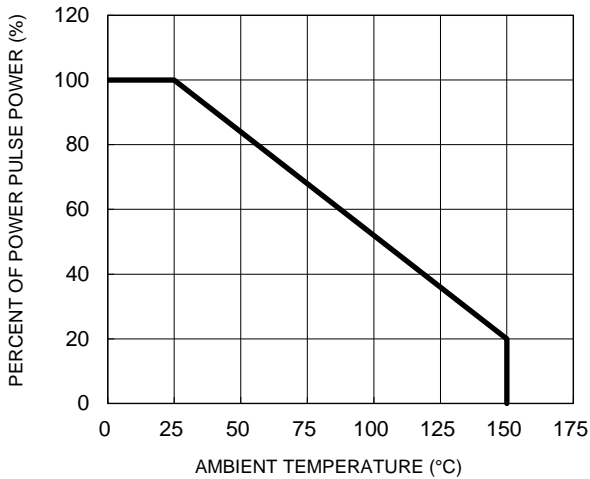

**Fig.2 Non-Repetitive Peak Pulse Power vs. Pulse Time**

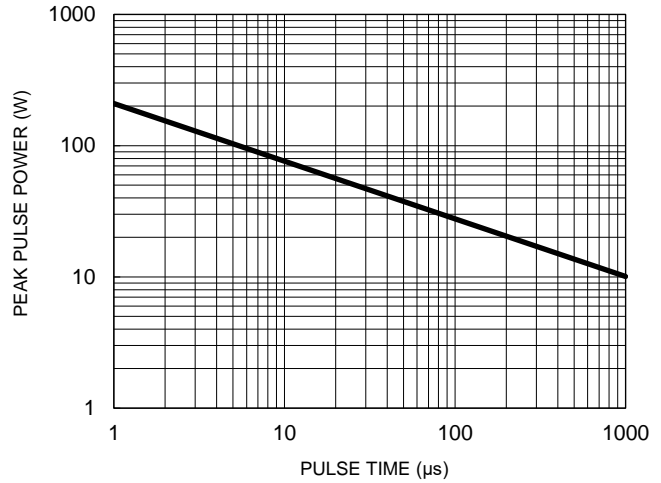

**Fig.3 Clamping Voltage vs. Peak Pulse Current**

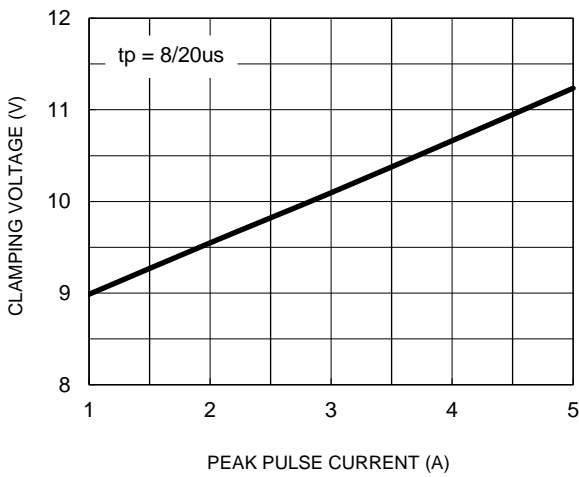

**Fig.4 Capacitance vs. Reverse Voltage**

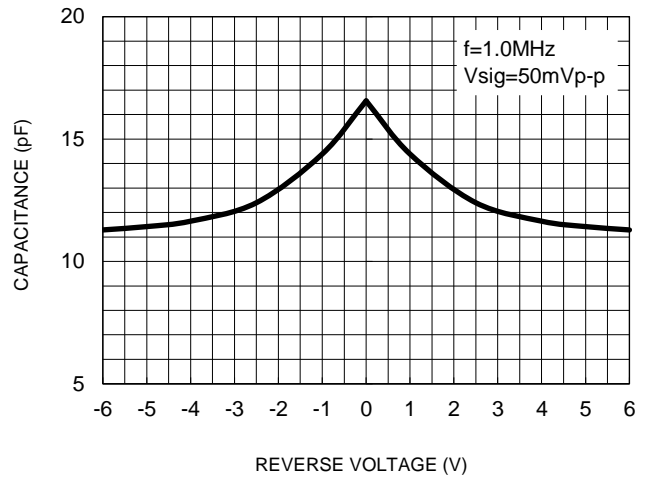

**Fig.5 TLP Curve**

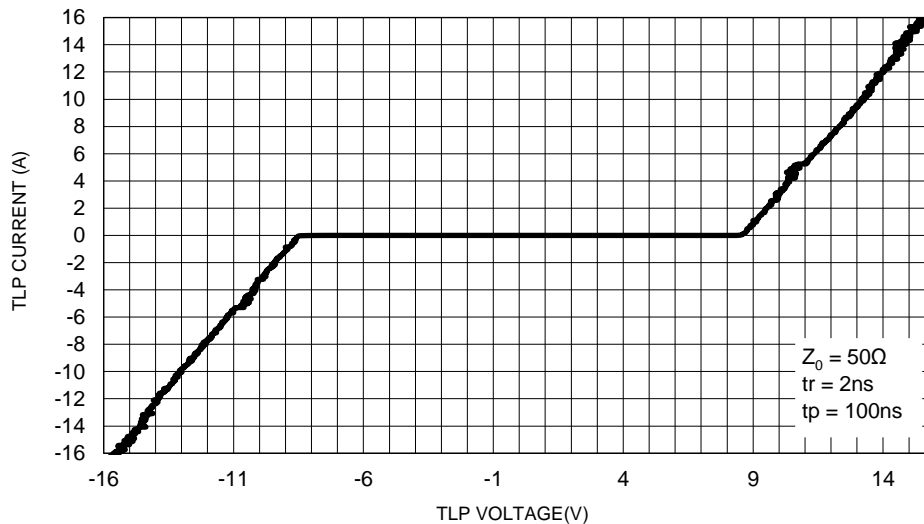

**CHARACTERISTICS CURVES**

(T<sub>A</sub> = 25°C unless otherwise noted)

**Fig.6 8/20μs pulse waveform per IEC61000-4-5**

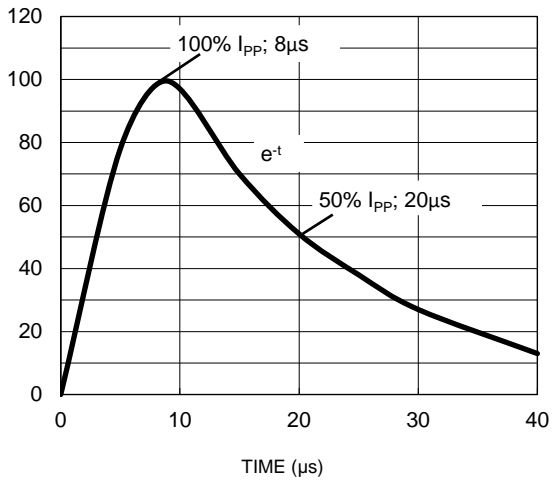

**Fig.7 ESD pulse waveform per IEC61000-4-2**

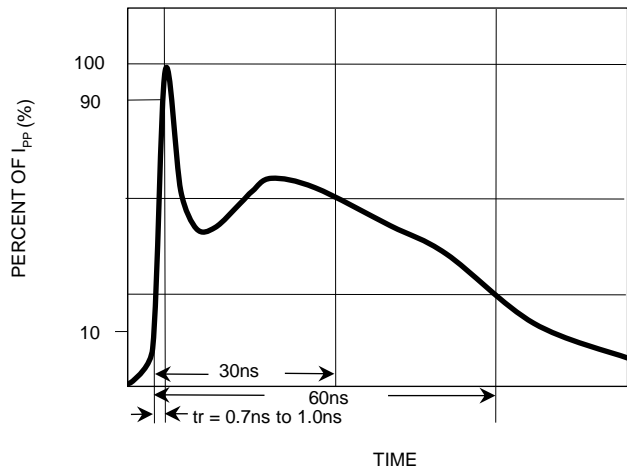

**APPLICATION INFORMATION**

**Device Connection**

The TESDA6V0B20P1Q0 is designed to protect one line against system ESD Lightning pulses by clamping it to an acceptable reference. It provides bidirectional protection.

The usage of the TESDA6V0B20P1Q0 is shown in Fig1. Protected line.

To minimize parasitic inductance in the board traces, all path lengths connected to the pins of TESDA6V0B20P1Q0 should be kept as short as possible.

To obtain enough suppression of ESD transient, a good circuit board is critical. Thus, the following guidelines are recommended:

- Let the path length between the protected lines and the TESDA6V0B20P1Q0 minimize.
- Place the TESDA6V0B20P1Q0 near the input terminals or connectors to restrict transient coupling.
- The ESD current return path to ground should be kept as short as possible.
- Use ground plane whenever possible.

**Fig.1 ESD protection by TESDA6V0B20P1Q0**

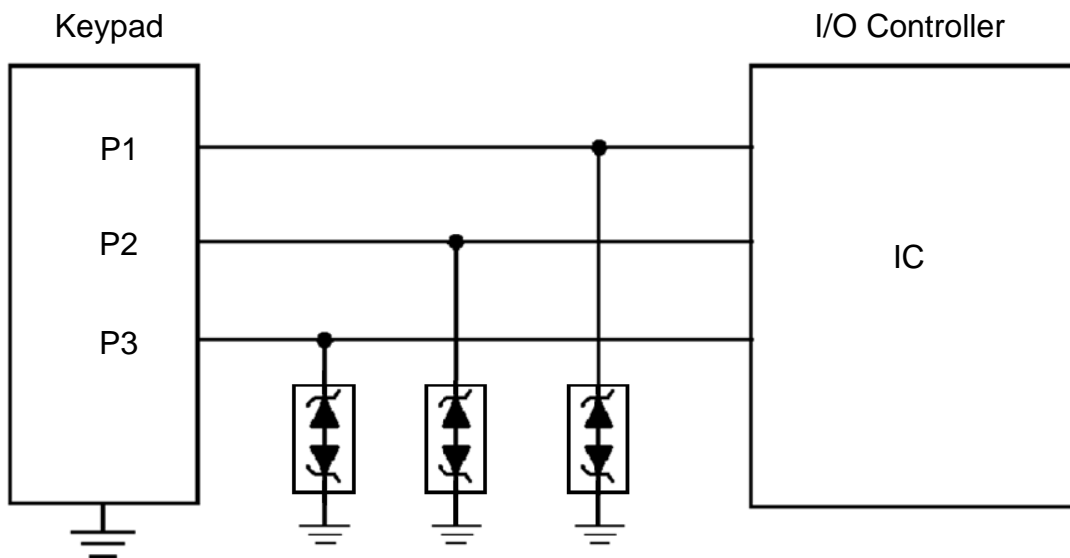

**PACKAGE OUTLINE DIMENSIONS**

**DFN0603-2L**

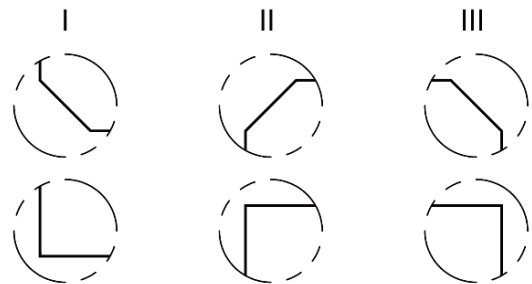
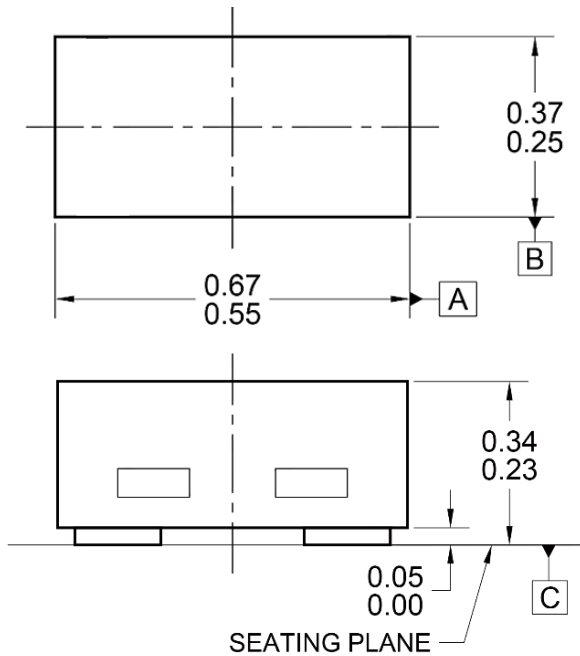

CATHODE TERMINAL CORNER NOTCH OPTION

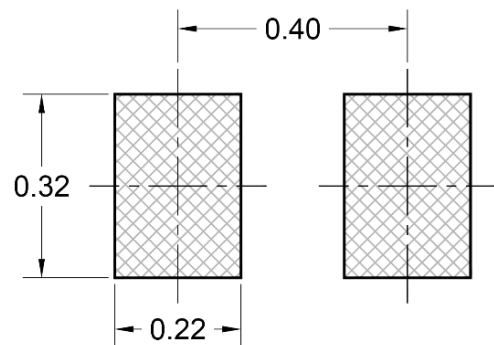
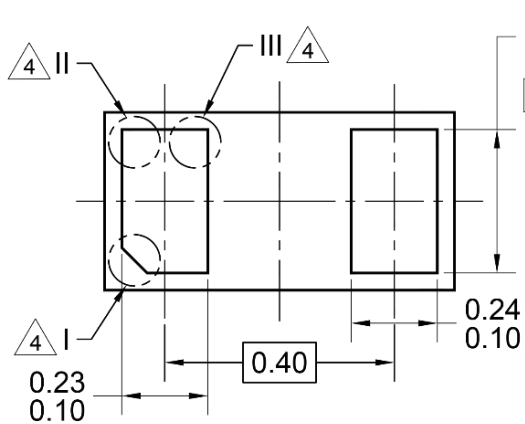

SUGGESTED PAD LAYOUT



MARKING DIAGRAM

DE = Device Code

NOTES: UNLESS OTHERWISE SPECIFIED

1. ALL DIMENSIONS ARE IN MILLIMETERS.
2. DIMENSIONING AND TOLERANCING PER ASME Y14.5M-1994.
3. PACKAGE SIZE CODE REFERENCE:  
EIA (inch) NAME: 0201 (0.024in x 0.012in)  
IEC (metric) NAME: 0603 (0.6mm x 0.3mm)

4. CATHODE TERMINAL MAY HAVE CHAMFER NOTCH OR FULL 90 DEGREES CORNER.

5. DWG NO. REF: HQ2SD07-DFN0603-067 REV C.

## **Notice**

Specifications of the products displayed herein are subject to change without notice. TSC or anyone on its behalf assumes no responsibility or liability for any errors or inaccuracies.

Purchasers are solely responsible for the choice, selection, and use of TSC products and TSC assumes no liability for application assistance or the design of Purchasers' products.

Information contained herein is intended to provide a product description only. No license, express or implied, to any intellectual property rights is granted by this document. Except as provided in TSC's terms and conditions of sale for such products, TSC assumes no liability whatsoever, and disclaims any express or implied warranty, relating to sale and/or use of TSC products including liability or warranties relating to fitness for a particular purpose, merchantability, or infringement of any patent, copyright, or other intellectual property right.

The products shown herein are not designed for use in medical, life-saving, or life-sustaining applications. Customers using or selling these products for use in such applications do so at their own risk and agree to fully indemnify TSC for any damages resulting from such improper use or sale.