

400W SMD Transient Voltage Suppressors

SMAJ5.0 ~ SMAJ440A/CA

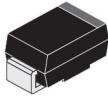

DO-214AC (SMA)

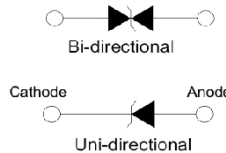

DO-214AC (SMA)
Surface Mount
Plastic Package
RoHS compliant

FEATURES:

1. Peak power dissipation 400W @10 x 1000 μ s Pulse
2. Low profile package.
3. Excellent clamping capability.
4. Glass passivated junction.
5. Very Fast response time.
6. Low reverse leakage current.
7. IEC 61000-4-2 ESD 30KV(Air), 30KV(Contact)
8. ESD protection of data lines in accordance with IEC 61000-4-2
9. EFT protection of data lines in accordance with IEC 61000-4-4
10. Lead-free finish
11. This product is available in AEC-Q101 Qualified and PPAP Capable also.

Note: For AEC-Q101 qualified products, please use suffix -AQ in the part number while ordering.

ABSOLUTE MAXIMUM RATINGS at ($T_a = 25^\circ\text{C}$ Unless otherwise specified)

PARAMETERS	SYMBOL	Value	Unit
Peak Pulse Power Dissipation on 10/1000 μ s Waveform (Note 1, 2, FIG.1)	P_{PPM}	400(min.)	W
Power Dissipation on Infinite Heat Sink at $T_L = 50^\circ\text{C}$	P_D	1	W
Peak Pulse Current of on 10/1000 μ s Waveform (Note 1, FIG.3)	I_{PPM}	See next table	Amps
Peak Forward Surge Current, 8.3ms Single Half Sine-Wave (Note 2, 3)	I_{FSM}	40	Amps
Thermal Resistance Junction to Ambient Air (Note 3.)	$R_{\theta JA}$	100	$^\circ\text{C/W}$
Thermal Resistance Junction to Leads	$R_{\theta JL}$	20	$^\circ\text{C/W}$
Operating Junction Temperature Range	T_J	-55 to 150	$^\circ\text{C}$
Storage Temperature Range	T_{STG}	-55 to 150	$^\circ\text{C}$

Notes:

1. Non-repetitive current pulse, per Fig.3 and derated above $T_A = 25^\circ\text{C}$ per Fig.2.
2. Mounted on 5.0x5.0mm² (0.03mm thick) Copper Pads to each terminal.
3. Measured on 8.3ms single half sine-wave, or equivalent square wave, for Unidirectional device only.



Continental Device India Pvt. Limited

An IATF 16949, ISO9001 and ISO 14001/ISO 45001 Certified Company



ELECTRICAL CHARACTERISTICS at ($T_a = 25\text{ }^\circ\text{C}$ Unless otherwise specified)

Device Type		Marking		Reverse Stand-Off Voltage	Break down Voltage Min. @ I_T	Break-down Voltage Max.@	Test Current	Max. Clamping Voltage@ I_{PP}	Peak Pulse current	Reverse Leakage @ V_{RMW}
Uni-directional	Bi-directional			V_{RMW}	$V_{BR\ MIN}$	$V_{BR\ MAX}$	I_T	V_C	I_{PP}	I_R
				(V)	(V)	(V)	(mA)	(V)	(A)	(μA)
SMAJ5.0A	SMAJ5.0CA	HE	TE	5.00	6.40	7.00	10.0	9.20	43.50	800
SMAJ6.0A	SMAJ6.0CA	HG	TG	6.00	6.67	7.37	10.0	10.30	38.80	800
SMAJ6.5A	SMAJ6.5CA	HK	TK	6.50	7.22	7.98	10.0	11.20	36.70	500
SMAJ7.0A	SMAJ7.0CA	HM	TM	7.00	7.78	8.60	10.0	12.00	33.30	200
SMAJ7.5A	SMAJ7.5CA	HP	TP	7.50	8.33	9.21	1	12.90	31.00	100
SMAJ8.0A	SMAJ8.0CA	HR	TR	8.00	8.89	9.83	1	13.60	29.40	50
SMAJ8.5A	SMAJ8.5CA	HT	TT	8.50	9.44	10.40	1	14.40	27.80	20
SMAJ9.0A	SMAJ9.0CA	HV	TV	9.00	10.00	11.10	1	15.40	26.00	10
SMAJ10A	SMAJ10CA	HX	TX	10.00	11.10	12.30	1	17.00	23.50	5
SMAJ11A	SMAJ11CA	HZ	TZ	11.00	12.20	13.50	1	18.20	22.00	1
SMAJ12A	SMAJ12CA	IE	UE	12.00	13.30	14.70	1	19.90	20.10	1
SMAJ13A	SMAJ13CA	IG	UG	13.00	14.40	15.90	1	21.50	18.60	1
SMAJ14A	SMAJ14CA	IK	UK	14.00	15.60	17.20	1	23.20	17.20	1
SMAJ15A	SMAJ15CA	IM	UM	15.00	16.70	18.50	1	24.40	18.40	1
SMAJ16A	SMAJ16CA	IP	UP	16.00	17.80	19.70	1	26.00	15.40	1
SMAJ17A	SMAJ17CA	IR	UR	17.00	18.90	20.90	1	27.60	14.50	1
SMAJ18A	SMAJ18CA	IT	UT	18.00	20.00	22.10	1	29.20	13.70	1
SMAJ20A	SMAJ20CA	IV	UV	20.00	22.20	24.50	1	32.40	12.30	1
SMAJ22A	SMAJ22CA	IX	UX	22.00	24.40	26.90	1	35.50	11.30	1
SMAJ24A	SMAJ24CA	IZ	UZ	24.00	26.70	29.50	1	38.90	10.30	1
SMAJ26A	SMAJ26CA	JE	VE	26.00	28.90	31.90	1	42.10	9.50	1
SMAJ28A	SMAJ28CA	JG	VG	28.00	31.10	34.40	1	45.40	8.80	1
SMAJ30A	SMAJ30CA	JK	VK	30.00	33.30	36.80	1	48.40	8.30	1
SMAJ33A	SMAJ33CA	JM	VM	33.00	36.70	40.60	1	53.30	7.50	1
SMAJ36A	SMAJ36CA	JP	VP	36.00	40.00	44.20	1	58.10	6.90	1
SMAJ40A	SMAJ40CA	JR	VR	40.00	44.40	49.10	1	64.50	6.20	1
SMAJ43A	SMAJ43CA	JT	VT	43.00	47.80	52.80	1	69.40	5.80	1
SMAJ45A	SMAJ45CA	JV	WE	45.00	50.00	55.30	1	72.70	5.50	1
SMAJ48A	SMAJ48CA	JX	VX	48.00	53.30	58.90	1	77.40	5.20	1
SMAJ51A	SMAJ51CA	JZ	VZ	51.00	56.70	62.70	1	82.40	4.90	1
SMAJ54A	SMAJ54CA	RE	WE	54.00	60.00	71.10	1	87.10	4.60	1
SMAJ58A	SMAJ58CA	RG	WG	58.00	66.40	71.20	1	93.60	4.30	1

SMAJ5.0- SMAJ440A/CA
Rev06 14062024M/SW/FZ

ELECTRICAL CHARACTERISTICS at ($T_a = 25\text{ }^\circ\text{C}$ Unless otherwise specified)

Device Type		Marking		Reverse Stand-Off Voltage	Break down Voltage Min. @ I_T	Break-down Voltage Max. @ I_T	Test Current	Max. Clamping Voltage @ I_{PP}	Peak Pulse current	Reverse Leakage @ V_{RMW}
Uni-directional	Bi-directional			V_{RMW}	$V_{BR\ MIN}$	$V_{BR\ MAX}$	I_T	V_C	I_{PP}	I_R
				(V)	(V)	(V)	(mA)	(V)	(A)	(μA)
SMAJ60A	SMAJ60CA	RK	WK	60.00	66.70	73.00	1	90.80	4.10	1
SMAJ64A	SMAJ64CA	RM	WM	64.00	71.10	78.60	1	103.00	3.90	1
SMAJ70A	SMAJ70CA	RP	WP	70.00	77.80	86.00	1	113.00	3.50	1
SMAJ75A	SMAJ75CA	RR	WR	75.00	83.30	92.10	1	121.00	3.30	1
SMAJ78A	SMAJ78CA	RT	WT	78.00	86.70	95.80	1	126.00	3.20	1
SMAJ85A	SMAJ85CA	RV	WV	85.00	94.40	104.00	1	137.00	2.90	1
SMAJ90A	SMAJ90CA	RX	WX	90.00	100.00	111.00	1	146.00	2.70	1
SMAJ100A	SMAJ100CA	RZ	WZ	100.00	111.00	123.00	1	162.00	2.50	1
SMAJ110A	SMAJ110CA	SE	XE	110.00	122.00	135.00	1	177.00	2.30	1
SMAJ120A	SMAJ120CA	SG	XG	120.00	133.00	147.00	1	193.00	2.10	1
SMAJ130A	SMAJ130CA	SK	XK	130.00	144.00	159.00	1	209.00	1.90	1
SMAJ150A	SMAJ150CA	SM	XM	150.00	167.00	185.00	1	243.00	1.60	1
SMAJ160A	SMAJ160CA	SP	XP	160.00	178.00	197.00	1	259.00	1.50	1
SMAJ170A	SMAJ170CA	SR	XR	170.00	189.00	209.00	1	275.00	1.50	1
SMAJ180A	SMAJ180CA	ST	XT	180.00	201.00	222.00	1	292.00	1.40	1
SMAJ190A	SMAJ190CA	SV	XV	190.00	211.00	233.00	1	308.00	1.30	1
SMAJ200A	SMAJ200CA	SX	XX	200.00	224.00	247.00	1	324.00	1.20	1
SMAJ210A	SMAJ210CA	SZ	XZ	210.00	237.00	263.00	1	340.00	1.20	1
SMAJ220A	SMAJ220CA	ZE	YE	220.00	246.00	272.00	1	356.00	1.10	1
SMAJ250A	SMAJ250CA	ZG	YG	250.00	279.00	309.00	1	405.00	1.00	1
SMAJ300A	SMAJ300CA	ZK	YK	300.00	335.00	371.00	1	486.00	0.80	1
SMAJ350A	SMAJ350CA	ZM	YM	350.00	391.00	432.00	1	567.00	0.70	1
SMAJ400A	SMAJ400CA	ZP	YP	400.00	447.00	494.00	1	648.00	0.60	1
SMAJ440A	SMAJ440CA	ZR	YR	440.00	492.00	543.00	1	713.00	0.60	1

Notes:

1. For Bi-directional type having V_{RMW} of 10 Volts and less, the I_R limit is double.
2. For parts without A, the V_{BR} is $\pm 10\%$ and V_C is 5% higher than with A parts.

I-V Curve Characteristics

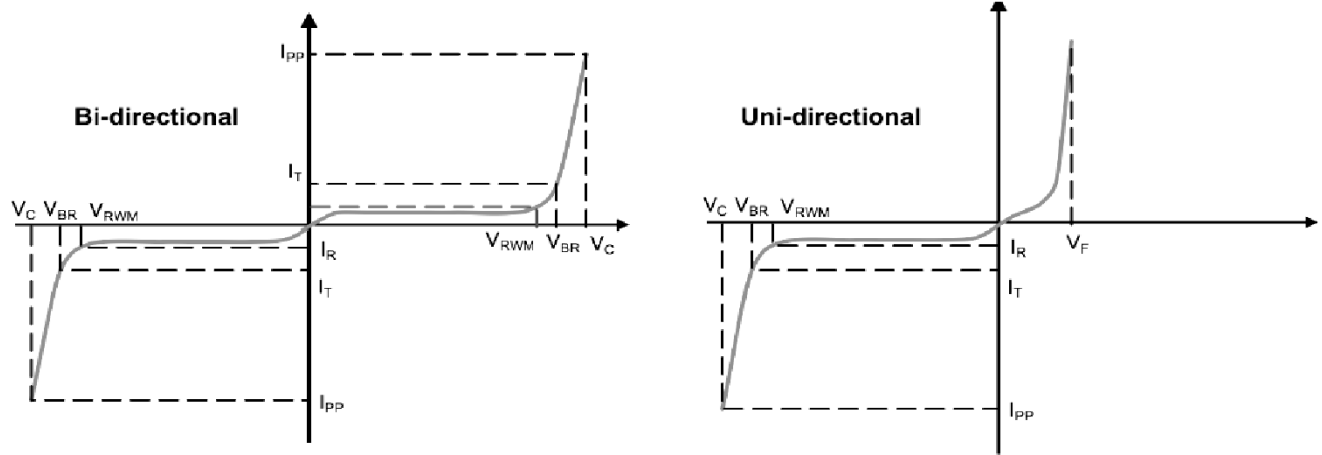

PPPM Peak Pulse Power Dissipation - Max power dissipation

VRWM Reverse Stand-off Voltage - Maximum voltage that can be applied to TVS without operation

VBR Breakdown Voltage – Maximum voltage that flows through the TVS at a specified current (I_T)

VC Clamping Voltage – Peak voltage measured across the TVS at a specified IPPM (peak impulse current)

IR Reverse Leakage Current – Current measured at VR

VF Forward Voltage Drop for Uni-directional

TYPICAL CHARACTERISTIC CURVES @ $T_A=25^{\circ}\text{C}$ unless otherwise specified

Fig.1 Peak Pulse Power Rating

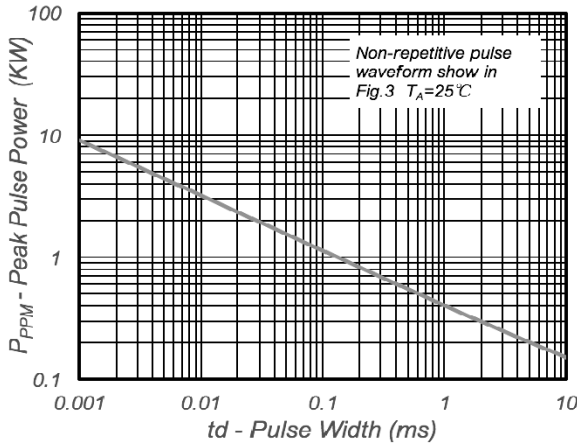

Fig.3 Pulse Waveform

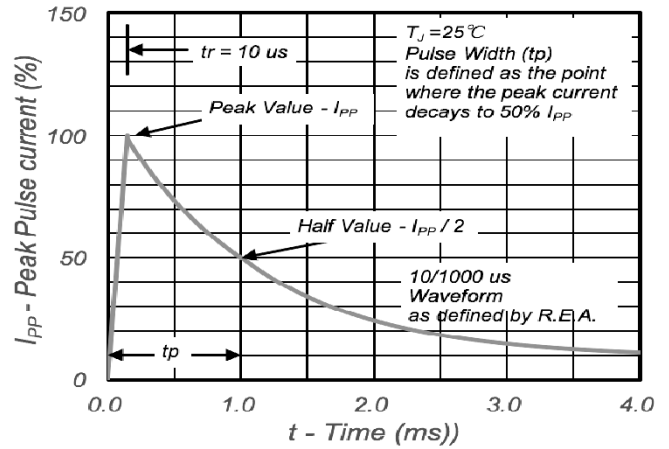

Fig.2 Pulse Derating Curve

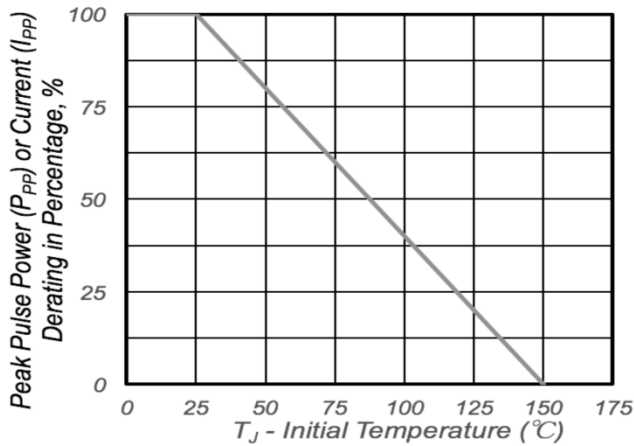
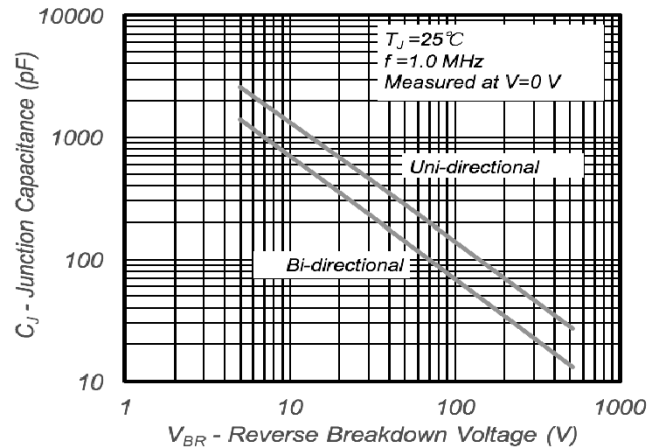
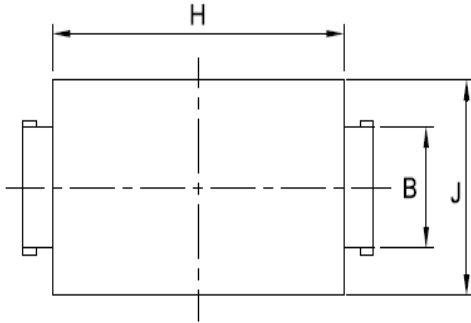

Fig.4 Typical Junction Capacitance



Package Details

Package DO-214AC (SMA)



DIM	MIN	MAX
A	1.90	2.65
B	1.25	1.65
C	0.05	0.20
D	0.15	0.40
E	0.75	1.52
F	1.90	2.45
G	4.80	5.35
H*	3.95	4.60
I	0.10	0.30
J*	2.40	2.95
K	1.70	1.90
N	7° TYP.	

* Dimensions H & J do not include mold flash, mold flash shall not exceed 0.13mm per side.

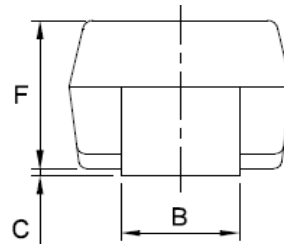
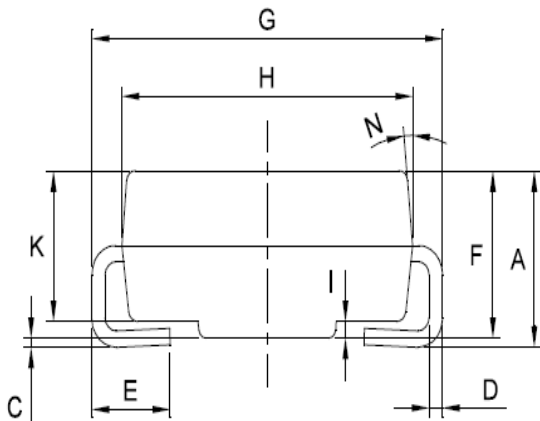

Suggested Pad Layout

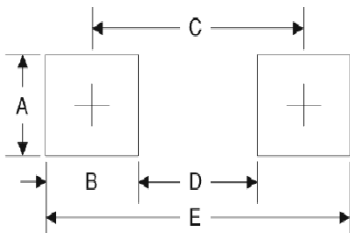

Symbol	Dim.(mm)
A	1.68 max
B	1.55 max
C	3.80 min
D	2.25 min
E	5.35 Ref

Packaging Information

Carrier Dimension(mm)

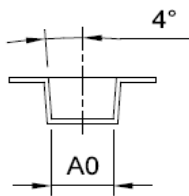
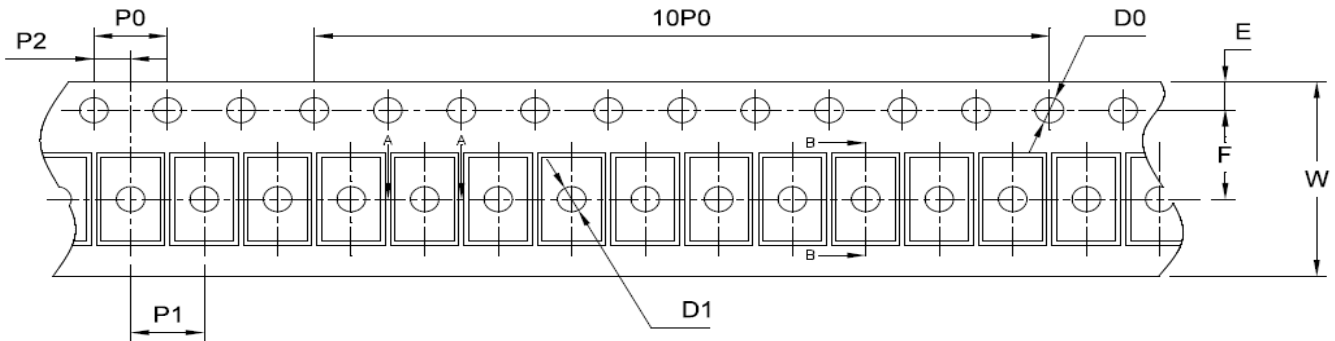

SECTION-AA

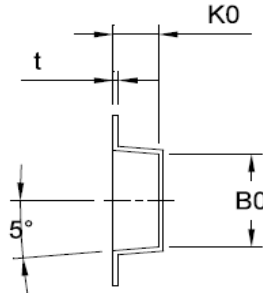

SECTION-BB

DIM.	SIZE/SPACIFICATION
E	1.75 ±0.10 = (1.65~1.85)
F	5.50 ±0.10 = (5.40~5.60)
P2	2.00 ±0.10 = (1.90~2.10)
D0	1.55 ±0.05 = (1.50~1.60)
D1	1.55 ±0.05 = (1.50~1.60)
P0	4.00 ±0.10 = (3.90~4.10)
10P0	40.00 ±0.20 = (39.80~40.20)

W	12.00 ±0.10 = (11.90~12.10)
P1	4.00 ±0.10 = (3.90~4.10)
A0	3.00 ±0.30 = (2.70~3.30)
B0	5.23 ±0.10 = (5.13~5.33)
K0	2.38 ±0.10 = (2.28~2.48)
t	0.25 ±0.03 = (0.22~0.28)

All dimensions are in mm

MECHANICAL DATA

Case : Molded plastic body

Terminals : Solder plated, Solderable per MIL-STD-750, Method 2026

Polarity : Polarity symbol marking on body for uni-directional only.

Mounting Position : Any

Weight : 0.0023 ounce, 0.07 grams

Packaging Specifications

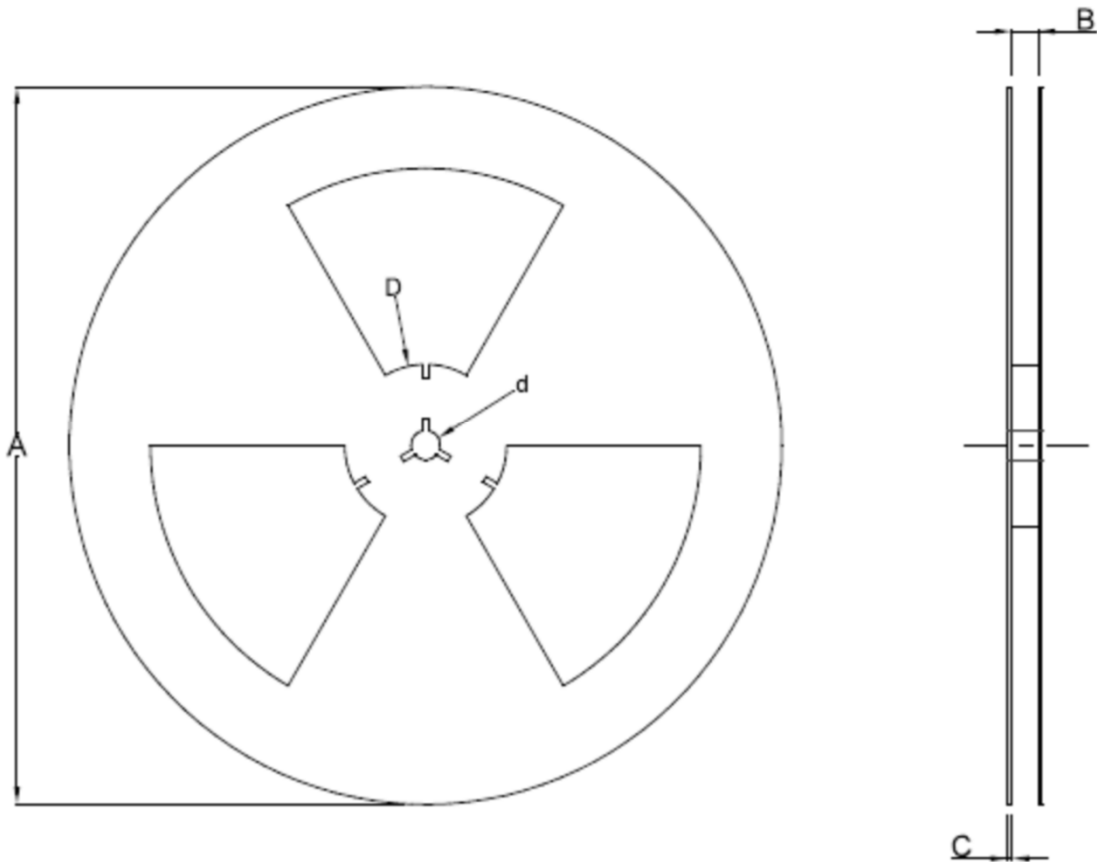

SIZE	13 INCH
OUTER DIA (A)	330 ^{+0.0} MM
INTERNAL SIZE (B)	12.5 ^{+0.0} MM
THICKNESS (C)	1.5 ^{+0.0} MM
CENTRAL DIA (D)	105.0 ^{+0.0} MM
INTERNAL DIA (d)	13.5 ^{+0.0} MM

Recommended Reflow Solder Profiles

The recommended reflow solder profiles for Pb and Pb-free devices are shown below.

Figure 1 shows the recommended solder profile for devices that have Pb-free terminal plating, and where a Pb-free solder is used.

Figure 2 shows the recommended solder profile for devices with Pb-free terminal plating used with leaded solder, or for devices with leaded terminal plating used with a leaded solder.

Figure 1

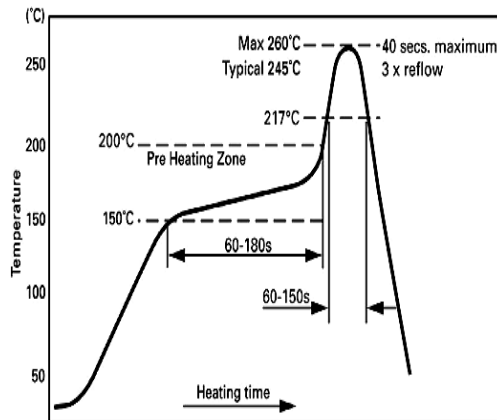
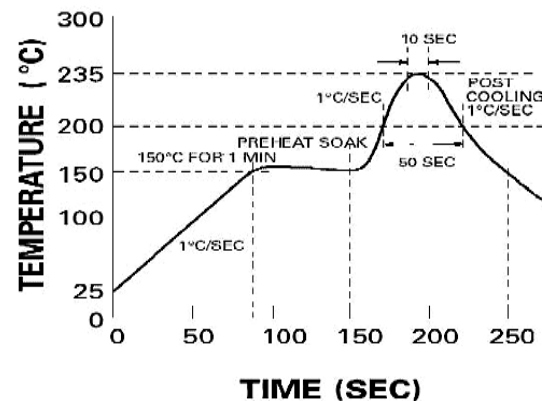

Figure 2



Reflow profiles in tabular form

Profile Feature	Sn-Pb System	Pb-Free System
Average Ramp-Up Rate	~3°C/second	~3°C/second
Preheat		
– Temperature Range	150-170°C	150-200°C
– Time	60-180 seconds	60-180 seconds
Time maintained above:		
– Temperature	200°C	217°C
– Time	30-50 seconds	60-150 seconds
Peak Temperature	235°C	260°C max.
Time within +0 -5°C of actual Peak	10 seconds	40 seconds
Ramp-Down Rate	3°C/second max.	6°C/second max.

Recommended Wave Solder Profiles

The Recommended solder Profile For Devices with Pb-free terminal plating where a Pb-free solder is used

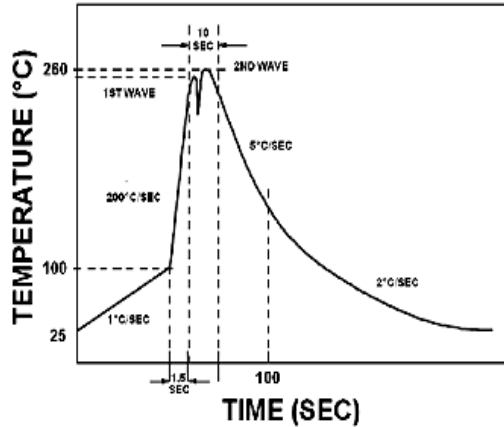

The Recommended solder Profile For Devices with Pb-free terminal plating used with leaded solder, or for devices with leaded terminal plating used with leaded solder

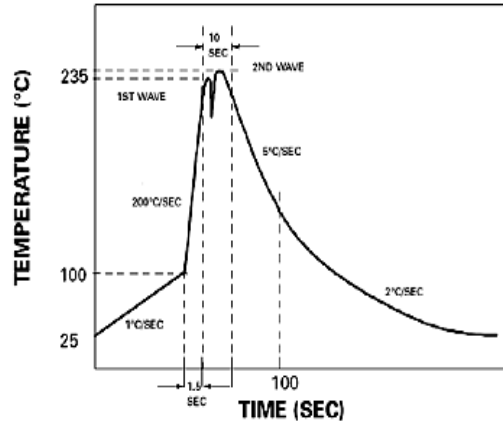

Wave Profiles in Tabular Form

Profile Feature	Sn-Pb System	Pb-free System
Average Ramp-Up Rate	~200°C/second	~200°C/second
Heating rate during preheat	Typical 1-2, Max 4°C/sec	Typical 1-2, Max 4°C/Sec
Final preheat Temperature	Within 125°C of Solder Temp	Within 125°C of Solder Temp
Peak Temperature	235°C	260°C max.
Time within +0 -5°C of actual Peak	10 seconds	10 seconds
Ramp-Down Rate	5°C/second max.	5°C/second max.



Continental Device India Pvt. Limited

An IATF 16949, ISO9001 and ISO 14001/ISO 45001 Certified Company



Recommended Product Storage Environment for Discrete Semiconductor Devices

This storage environment assumes that the Diodes and transistors are packed properly inside the original packing supplied by CDIL.

- Temperature 5 °C to 30 °C
- Humidity between 40 to 70 %RH
- Air should be clean.
- Avoid harmful gas or dust.
- Avoid outdoor exposure or storage in areas subject to rain or water spraying .
- Avoid storage in areas subject to corrosive gas or dust. Product shall not be stored in areas exposed to direct sunlight.
- Avoid rapid change of temperature.
- Avoid condensation.
- Mechanical stress such as vibration and impact shall be avoided.
- The product shall not be placed directly on the floor.
- The product shall be stored on a plane area. They should not be turned upside down. They should not be placed against the wall.

Shelf Life of CDIL Products

The shelf life of products is the period from product manufacture to shipment to customers. The product can be unconditionally shipped within this period. The period is defined as 2 years.

If products are stored longer than the shelf life of 2 years the products shall be subjected to quality check as per CDIL quality procedure.

The products are further warranted for another one year after the date of shipment subject to the above conditions in CDIL original packing.

Floor Life of CDIL Products and MSL Level

When the products are opened from the original packing, the floor life will start.

For this, the following JEDEC table may be referred:

JEDEC MSL Level		
Level	Time	Condition
1	Unlimited	≤30 °C / 85% RH
2	1 Year	≤30 °C / 60% RH
2a	4 Weeks	≤30 °C / 60% RH
3	168 Hours	≤30 °C / 60% RH
4	72 Hours	≤30 °C / 60% RH
5	48 Hours	≤30 °C / 60% RH
5a	24 Hours	≤30 °C / 60% RH
6	Time on Label(TOL)	≤30 °C / 60% RH

SMAJ5.0- SMAJ440A/CA
Rev06 14062024M/SW/FZ



Continental Device India Pvt. Limited

An IATF 16949, ISO9001 and ISO 14001/ISO 45001 Certified Company



Customer Notes

Component Disposal Instructions

1. CDIL Semiconductor Devices are RoHS compliant, customers are requested to please dispose as per prevailing Environmental Legislation of their Country.
2. In Europe, please dispose as per EU Directive 2002/96/EC on Waste Electrical and Electronic Equipment (WEEE).

Disclaimer

The product information and the selection guides facilitate selection of the CDIL's Semiconductor Device(s) best suited for application in your product(s) as per your requirement. It is recommended that you completely review our Data Sheet(s) so as to confirm that the Device(s) meet functionality parameters for your application. The information furnished in the Data Sheet and on the CDIL Web Site/CD are believed to be accurate and reliable. CDIL however, does not assume responsibility for inaccuracies or incomplete information. Furthermore, CDIL does not assume liability whatsoever, arising out of the application or use of any CDIL product; neither does it convey any license under its patent rights nor rights of others. These products are not designed for use in life saving/support appliances or systems. CDIL customers selling these products (either as individual Semiconductor Devices or incorporated in their end products), in any life saving/support appliances or systems or applications do so at their own risk and CDIL will not be responsible for any damages resulting from such sale(s).

CDIL strives for continuous improvement and reserves the right to change the specifications of its products without prior notice.



CDIL is a registered trademark of

Continental Device India Pvt. Limited

C-120 Naraina Industrial Area, New Delhi 110 028, India.

Telephone +91-11-2579 6150, 4141 1112 Fax +91-11-2579 5290, 4141 1119

email@cdil.com www.cdil.com

CIN No. U32109DL1964PTC004291

SMAJ5.0- SMAJ440A/CA
Rev06 14062024M/SW/FZ