

Layout proposal/
Layout Vorschlag

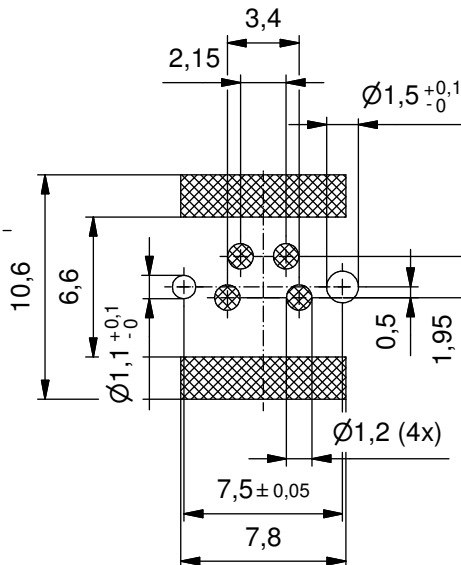

Technical specification:

Technische Daten:

Rated Voltage/ Bemessungsspannung: IEC 61076-2-104	50 V AC / 60 V DC
Current rating/ Strombelastbarkeit: IEC 61076-2-104	4 A bei 40°C
Insulation resistance/ Isolationswiderstand: IEC 60512	>=100 MΩ
Pollution degree/ Verschmutzungsgrad: IEC 60664-1	3/2
Degree of protection/ Schutzart: IEC 60529	IP 67, mated condition/ im verbauten Zustand
Temperature range/ Umgebungstemperatur: EN 60512-11-10 EN 60512-11-4	-25°C ... +95°C -40°C -40°C ... +85°C
Mating cycles/ Steckzyklen: IEC 60512-9a	>=100

Materials/

Werkstoffe:

Contact/ Kontakt:	CuZn, Ni b / Au 0,2 gal.
Contact carrier/ Kontaktträger:	LCP GF, UL 94 V-0
Soldering sheet/ Lötblech:	CuZn, Ni / Sn
Sealing/ Dichtung:	FPM / NBR
Socket housing/ Flanschgehäuse:	CuZn, Ni

Suitable for reflow soldering

max. 60s / 250°C/
Geeignet für Reflow Lötprozess
max. 60s / 250°C



Coplanarity of all contacts and
soldering sheets max 0,1mm/
Koplanarität aller Kontakte und
Lötbleche max 0,1mm

Installation specification/

Montagedaten:

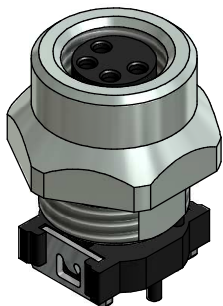
Recommended torque/ empfohlenes Drehmoment:	1-1,2 Nm
Conec Installation tool/ Montagewerkzeug:	Torque wrench/ Drehmomentschlüssel: 36-000200 Insert across flats 13/ Steckeinsatz SW13: 36-000220
Installation hole/ Einbauöffnung:	See fig.2 42K1A1119 siehe Fig.2 42K1A1119

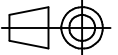

Part no. packing unit tape & reel/ Art.-Nr. Verpackungseinheit Rolle:	42-01245TR	Part no. packing unit in bulk/ Art.-Nr. Verpackungseinheit lose:	42-01245	Description/ Bezeichnung:	SAL - 8 - FK4 - X9 / SMT	Pos/ Pol.:	4	
 dim. in mm		Female socket M8x1, SMT, frontmounting Flanschkupplung M8x1 SMT, Frontmontage						
general tolerance/ Allgemeintoleranz:	0 ± 0,50mm 0,0 ± 0,25mm 0,00 ± 0,10mm * ± 5°						Date/ Datum	Name
drawn/ gez.	23.02.15						Gitinow	
appd./ gepr.	17.03.15						Schramm	
Index: Index: "b" 09.06.17 cbe Ä6740	scale/ Maßstab:			dwg no / Z.-nr.:	42K1A771	DIN- A4		
Status: InBearbeitung	2,5:1							
RoHS & REACH compliant/konform								
							1 / 1	

The reproduction, distribution and utilization of this document as well as the communication of its contents to others without express authorization is prohibited. Offenders will be held liable for the payment of damages. All rights reserved in the event of the grant of a patent, utility model or design. Weitergabe sowie Vervielfältigung dieses Dokuments, Verwertung und Mitteilung seines Inhalts sind verboten, soweit nicht ausdrücklich gestattet. Zuwiderhandlungen verpflichten zu Schadenersatz. Alle Rechte für den Fall der Patent-, Gebrauchsmuster- oder Geschmacksmustereintragung vorbehalten.