

DISPLAY Elektronik GmbH

DATA SHEET

LCD MODULE

DEM 080160C VMH-PW-N

Product Specification

Version: 4

09.09.2024

CONTENTS

1. GENERAL SPECIFICATIONS..... 2

2. EXTERNAL DIMENSIONS 3

3. BLOCK DIAGRAM 4

4. PIN ASSIGNMENT 4

5. OPTICAL CHARACTERISTICS..... 5

6. ABSOLUTE MAXIMUM RATINGS 8

7. ELECTRICAL CHARACTERISTICS 8

8. TIMING CHARACTERISTICS..... 9

9. RELIABILITY TEST 11

10. LCD MODULES HANDLING PRECAUTIONS..... 12

11. OTHERS 12

1. GENERAL SPECIFICATIONS

Item	Contents	Unit
LCD TYPE	IPS TFT	-
MODULE SIZE	13.50 x 27.95 x 1.54	mm
ACTIVE SIZE	10.800 x 21.696	mm
PIXEL PITCH	0.153 x 0.153	mm
NUMBER OF DOTS	80 x 160	-
DRIVER IC	ST7735V3	-
INTERFACE TYPE	SPI	-
RECOMMEND VIEWING DIRECTION	ALL	O'CLOCK
GRAY SCALE INVERSION DIRECTION		O'CLOCK
COLORS	262k	-
BACKLIGHT TYPE	1-DIES WHITE LED	-
TOUCH PANEL TYPE	WITHOUT	-

2. EXTERNAL DIMENSIONS

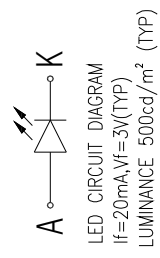
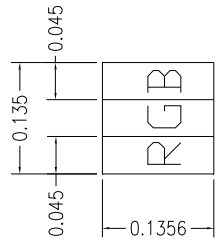
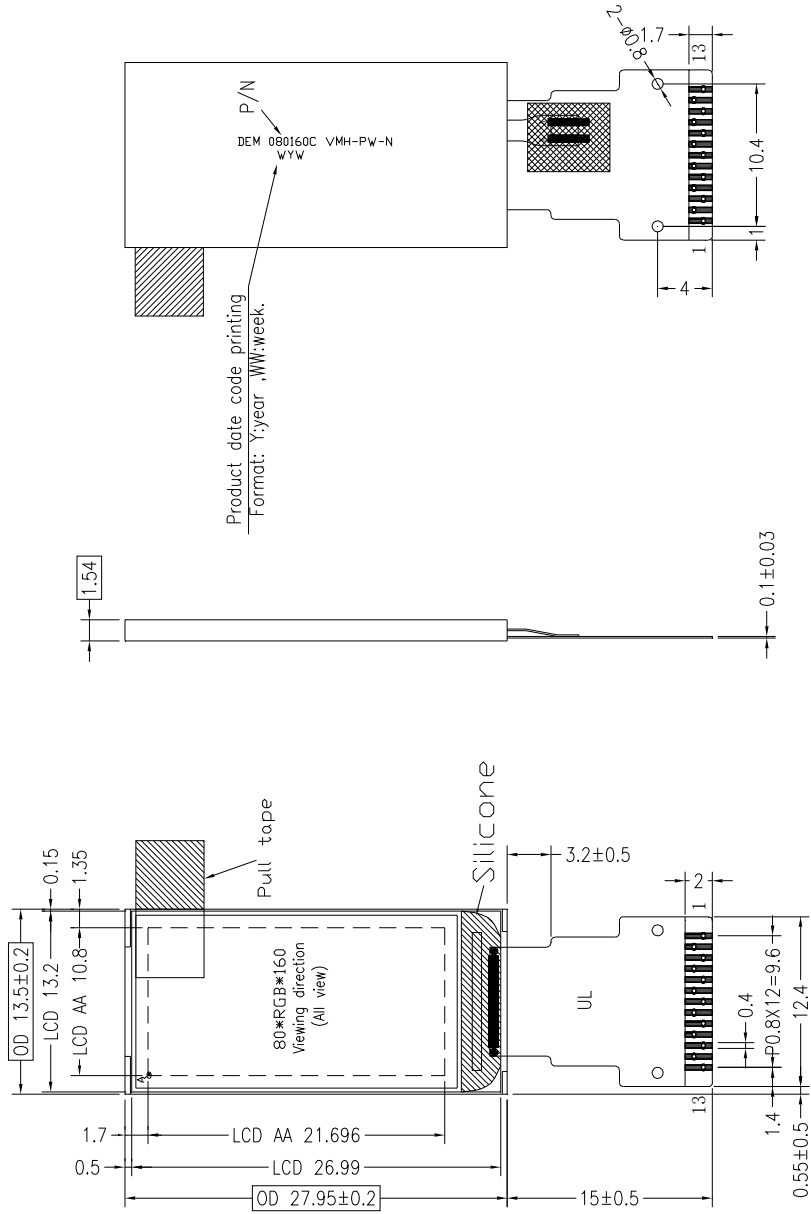

SCALE A 60:1

Remark:
 1.Unmarked tolerance is ±0.3
 2.All materials comply with RoHS
 3. Critical dimension
 4.50000 LED Lifetime

3. BLOCK DIAGRAM

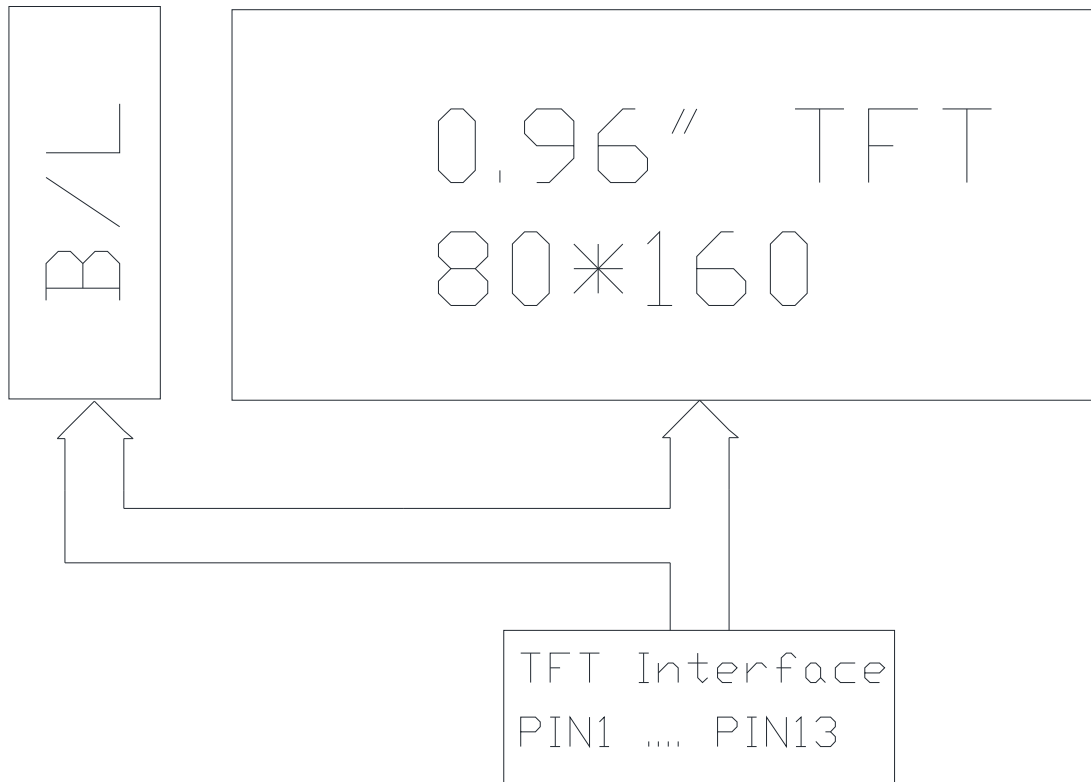

4. PIN ASSIGNMENT

Pin No.	Symbol	Description
1	SPI4W	SPI4W='0',3-wire SPI SPI4W='1',4- wire SPI
2	NC	No Connection
3	SDA	Serial Interface Data
4	SCL	Serial Interface Clock
5	RS	Data/Command Selection Pin(4-wire SPI uses)
6	RES	Reset Pin(Low Active)
7	CS	Chip SELECTION pin(Low Active)
8	GND	Ground
9	NC	No Connection
10	VDD	Power Supply
11	LEDK	Backlight Cathode
12	LEDA	Backlight Anode
13	GND	Ground

5. OPTICAL CHARACTERISTICS

ITEM	SYMBOL	CONDITIONS	SPECIFICATIONS			UNIT	NOTE	
			MIN	TYP.	MAX			
Luminance	L	-	-	500	-	Cd/m ²	-	
Contrast ratio	CR	$\theta = 0^\circ$	-	800	-	-	-	
Response time	T _R +T _F	25°C	-	30	40	ms	-	
CIE COLOUR COORDINATE	RED	RX	VIEWING NORMAL ANGLE	-0.02	+0.02	-	-	
		RY				-	-	
	GREEN	GX				-	-	
		GY				-	-	
	BLUE	BX				-	-	
		BY				-	-	
	WHITE	WX				-	-	
		WY				-	-	
VIEWING ANGLE	Hor.	θ_{x+}	CR ≥ 10	-	80	-	Degree	-
		θ_{x-}		-	80	-		-
	Ver.	θ_{y+}		-	80	-		-
		θ_{y-}		-	80	-		-

Note 1: Definition of Viewing Angle θ_x and θ_y :

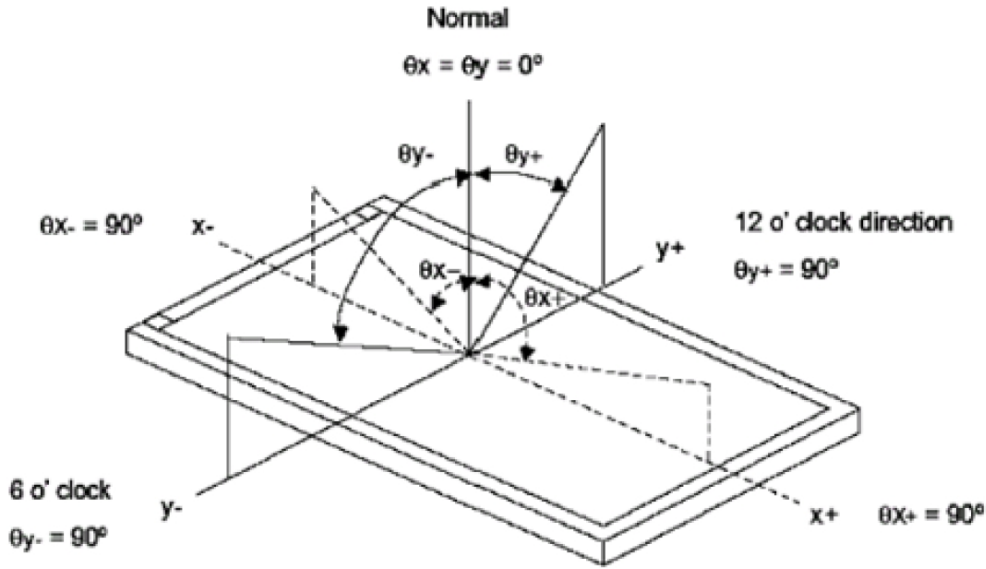

Note 2: Definition of contrast ratio CR:

$$CR = \frac{\text{Luminance of white state}}{\text{Luminance of black state}}$$

Note 3: Definition of Response Time (T_r, T_f)

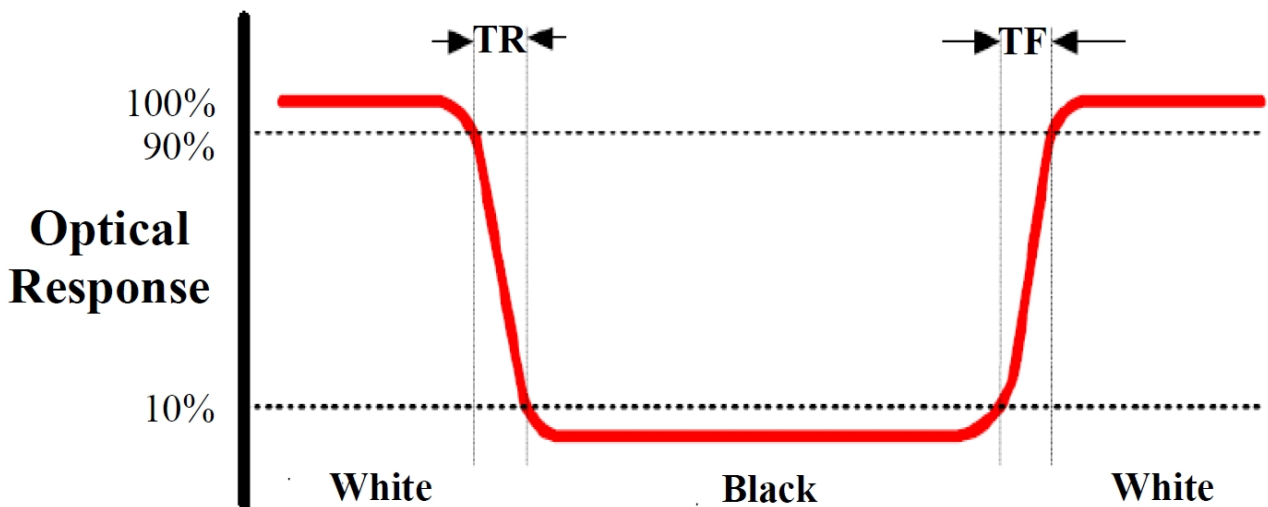

Note 4: Definition of Luminance

① The Brightness Test Equipment Setup

Field=2° (As measuring “black” image, field=2° is the best testing condition)

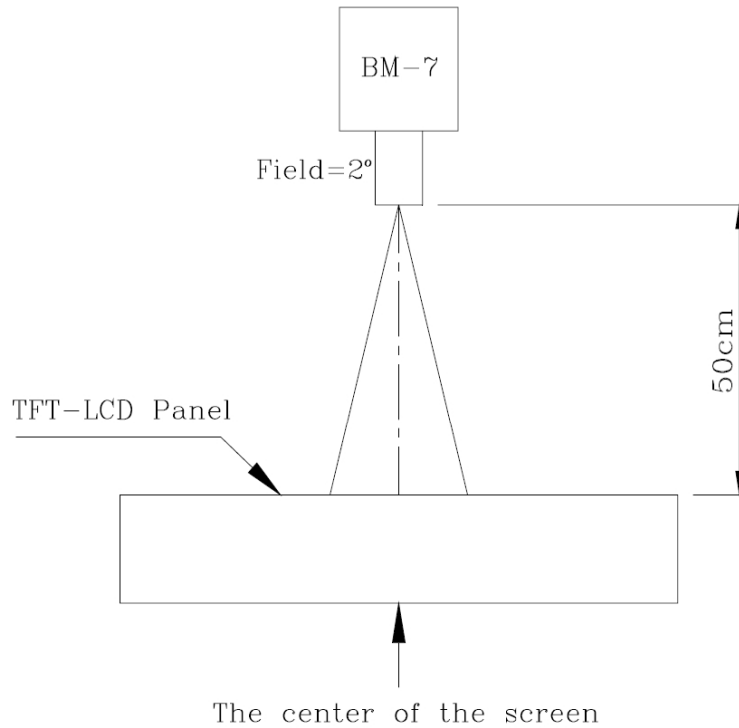

② The Brightness Test Point Setup

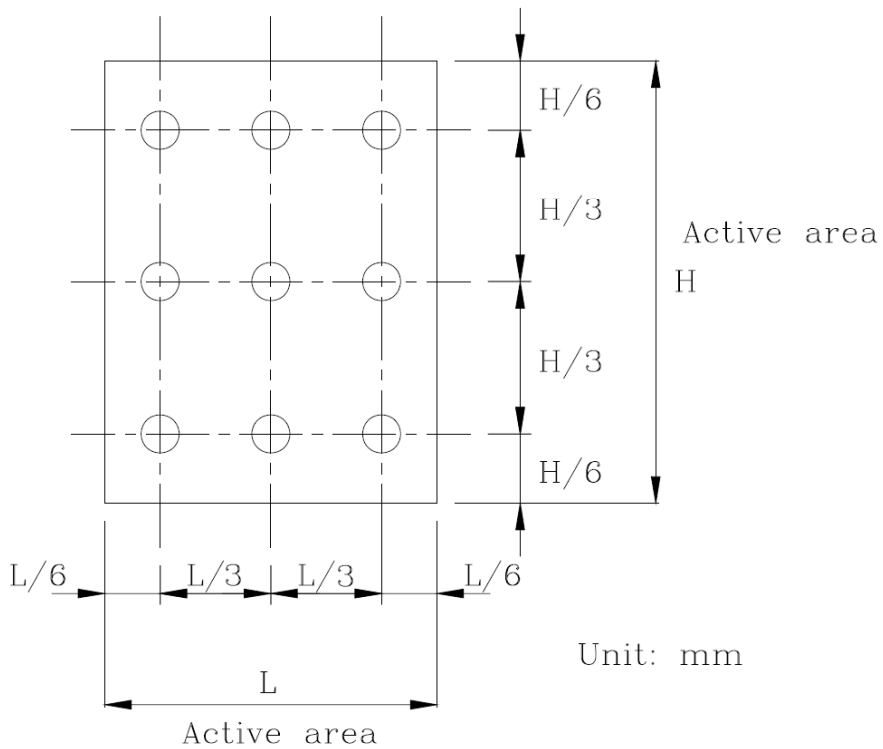

6. ABSOLUTE MAXIMUM RATINGS

Parameter	Symbol	Min	Max	Unit
Supply Voltage for Analog	VDD	-0.3	4.6	V
Operating Temperature	T_{OP}	-20	+70	°C
Storage Temperature	T_{ST}	-30	+80	°C

Note: The absolute maximum rating values of this product are not allowed to be exceeded at any times. Should a module be used with any of the absolute maximum ratings exceeded, the characteristics of the module may not be recovered, or in an extreme case, the module may be permanently destroyed.

7. ELECTRICAL CHARACTERISTICS

7.1 Input Power

Item	Symbol	Min	Typ.	Max	Unit	Applicable terminal
Supply Voltage for Analog and Logic	VDD	2.5	2.75	3.7	V	-
Input Voltage	V_{IL}	GND	-	0.3VDD	V	-
	V_{IH}	0.7VDD	-	VDD	V	-

7.2 Backlight Driving Conditions

Item	Symbol	Value			Unit	Remark
		Min	Typ.	Max		
Voltage for LED Backlight	V_L	-	3	-	V	-
Current for LED Backlight	I_L	-	20	-	mA	-
Power Consumption	P	-	0.06	-	W	-
LED Lifetime	-	-	50000	-	Hr	-

8. TIMING CHARACTERISTICS

Serial Interface Characteristic (4-line Serial)

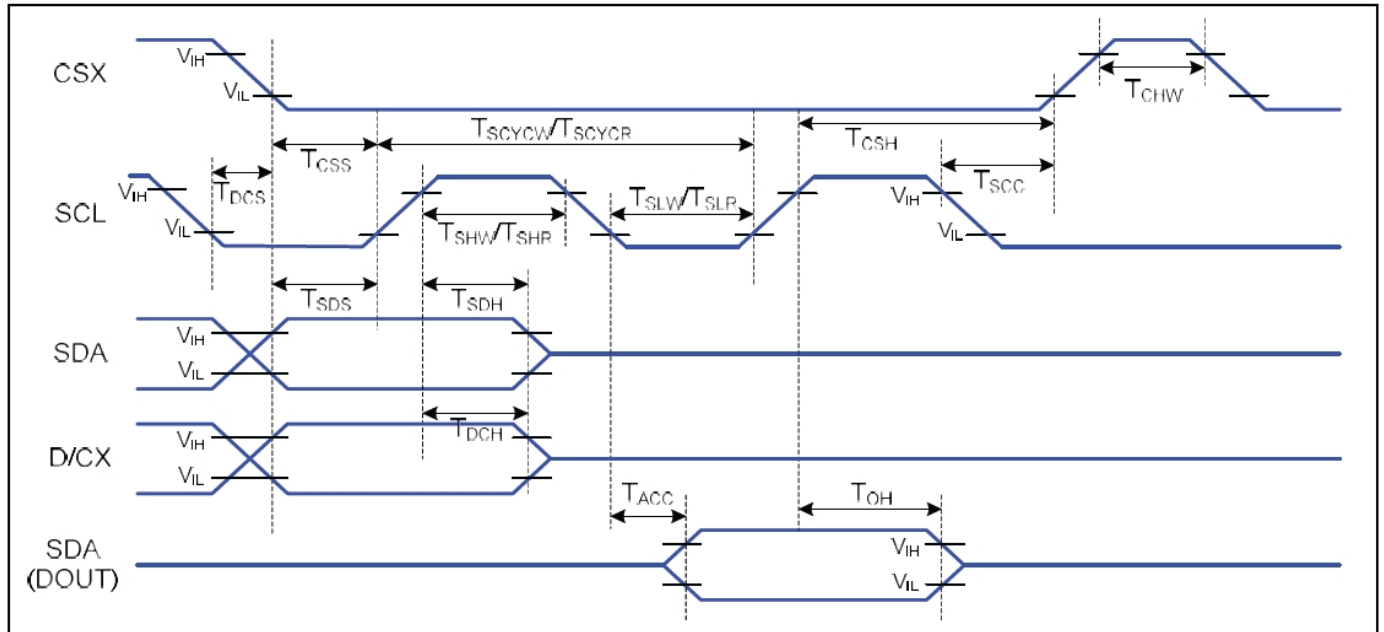

Signal	Symbol	Parameter	MIN	MAX	Unit	Description
CSX	TCSS	Chip Select Setup Time (Write)	45		ns	
	TCSH	Chip Select Hold Time (Write)	45		ns	
	TCSS	Chip Select Setup Time (Read)	60		ns	
	TSCC	Chip Select Hold Time (Read)	65		ns	
	TCHW	Chip Select "H" Pulse Width	40		ns	
SCL	TSCYCW	Serial Clock Cycle (Write)	20		ns	-Write Command & Data Ram
	TSHW	SCL "H" Pulse Width (Write)	10		ns	
	TSLW	SCL "L" Pulse Width (Write)	10		ns	
	TSCYCR	Serial Clock Cycle (Read)	150		ns	-Read Command & Data Ram
	TSHR	SCL "H" Pulse Width (Read)	60		ns	
	TSLR	SCL "L" Pulse Width (Read)	60		ns	
D/CX	TDCS	D/CX Setup Time	10		ns	
	TDCH	D/CX Hold Time	10		ns	
SDA (DIN) (DOUT)	TSDS	Data Setup Time	10		ns	For Maximum CL=30pF For Minimum CL=8pF
	TSDH	Data Hold Time	10		ns	
	TACC	Access Time	10	50	ns	
	TOH	Output Disable Time	15	50	ns	

Serial Interface Characteristic (3-line Serial)

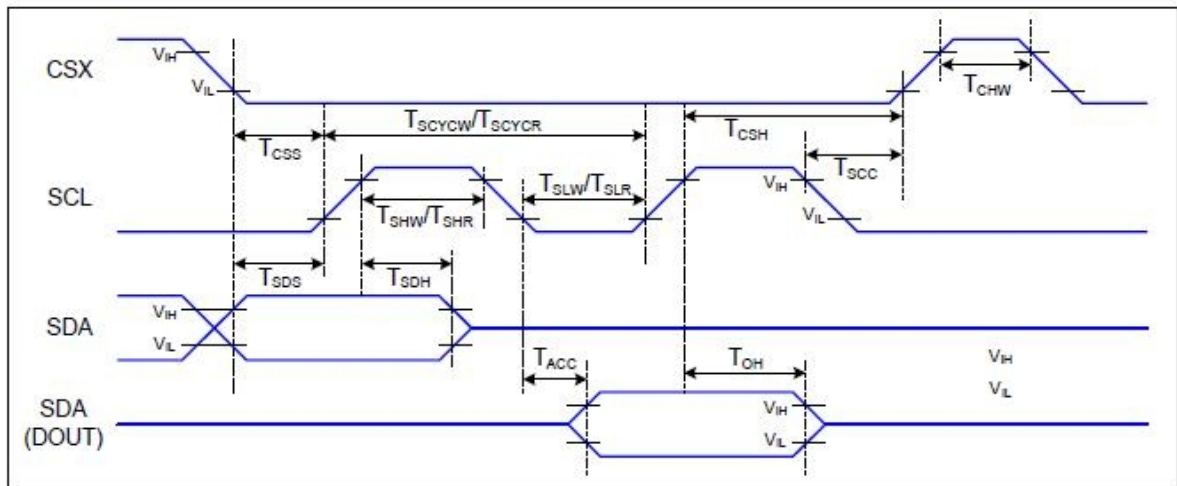

Figure 6 3-line Serial Interface Timing

T_a=25 °C, V_{DDI}=1.65~3.7V, V_{DD}=2.5~3.7V

Signal	Symbol	Parameter	Min	Max	Unit	Description
CSX	TCSS	Chip Select Setup Time (Write)	15		ns	
	TCSH	Chip Select Hold Time (Write)	15		ns	
	TCSS	Chip Select Setup Time (Read)	60		ns	
	TSCC	Chip Select Hold Time (Read)	65		ns	
	TCHW	Chip Select "H" pulse width	40		ns	
SCL	TSCYW	Serial Clock Cycle (Write)	20		ns	
	TSHW	SCL "H" Pulse Width (Write)	10		ns	
	TSLW	SCL "L" Pulse Width (Write)	10		ns	
	TSCYCR	Serial Clock Cycle (Read)	150		ns	
	TSHR	SCL "H" Pulse Width (Read)	60		ns	
	TSLR	SCL "L" Pulse Width (Read)	60		ns	
SDA (DIN) (DOUT)	TSDS	Data Setup Time	10		ns	For Maximum CL=30pF For Minimum CL=8pF
	TSDH	Data Hold Time	10		ns	
	TACC	Access Time	10	50	ns	
	TOH	Output Disable Time	15	50	ns	

9. RELIABILITY TEST

NO.	TEST ITEM	CONDITIONS
1	HIGH TEMPERATURE STORAGE	TA=+80°C, 240H
2	LOW TEMPERATURE STORAGE	TA=-30°C, 240H
3	HIGH TEMPERATURE OPERATION	TA=+70°C, 240H
4	LOW TEMPERATURE OPERATION	TA=-20°C, 240H
5	HIGH TEMPERATURE AND HIGH HUMIDITY OPERATION	+60°C, 90%RH, 240H

10. LCD MODULES HANDLING PRECAUTIONS

- The display panel is made of glass. Do not subject it to a mechanical shock by dropping it from a high place, etc.
- If the display panel is damaged and the liquid crystal substance inside it leaks out, do not get any in your mouth. If
- The substance come into contact with your skin or clothes promptly wash it off using soap and water.
- Do not apply excessive force to the display surface or the adjoining areas since this may cause the color tone to vary.
- The polarizer covering the display surface of the LCD module is soft and easily scratched. Handle this polarize carefully.
- To prevent destruction of the elements by static electricity, be careful to maintain an optimum work environment.
 - Be sure to ground the body when handling the LCD module.
 - Tools required for assembly, such as soldering irons, must be properly grounded.
 - To reduce the amount of static electricity generated, do not conduct assembly and other work under dry conditions.
 - The LCD module is coated with a film to protect the display surface. Exercise care when peeling off this protective film since static electricity may be generated.
- Storage precautions
When storing the LCD modules, avoid exposure to direct sunlight or to the light of fluorescent lamps. Keep the modules in bags designed to prevent static electricity charging under low temperature / normal humidity conditions (avoid high temperature / high humidity and low temperatures below 0°C). Whenever possible, the LCD modules should be stored in the same conditions in which they were shipped from our company.

11. OTHERS

- Liquid crystals solidify at low temperature (below the storage temperature range) leading to defective orientation of liquid crystal or the generation of air bubbles (black or white). Air bubbles may also be generated if the module is subjected to a strong shock at a low temperature.
- If the LCD modules have been operating for a long time showing the same display patterns may remain on the screen as ghost images and a slight contrast irregularity may also appear. Abnormal operating status can be resumed to be normal condition by suspending use for some time. It should be noted that this phenomena does not adversely affect performance reliability.
- To minimize the performance degradation of the LCD modules resulting from caused by static electricity, etc. exercise care to avoid holding the following sections when handling the modules:
 - Exposed area of the printed circuit board
 - Terminal electrode sections.