

Display Elektronik GmbH

DATA SHEET

TFT MODULE

DEM 240320E1 TTH-PW

2,4“ transfl. TFT

Product Specification

Version: 1

29.10.2024

Contents

- 1. Block Diagram..... 5**
- 2. Outline dimension..... 6**
- 3. Input terminal Pin Assignment..... 7**
- 4. LCD Optical Characteristics 9**
 - 4.1 Optical specification (Reflective) 9
 - 4.2 Optical specification (Transmittance)..... 10
- 5. Electrical Characteristics 12**
 - 5.1 Absolute Maximum Rating (Ta=25 VSS=0V) 12
 - 5.2 DC Electrical Characteristics..... 13
 - 5.3 LED Backlight Characteristics 13
- 6. AC Characteristic..... 15**
 - 6.1 8080 Series MCU Parallel Interface Characteristics: 18/16/9/8-bit Bus..... 15
 - 6.2 Serial Interface Characteristics (3-line serial)..... 17
 - 6.3 Serial Interface Characteristics (4-line serial)..... 18
 - 6.4 RGB Interface Characteristics..... 19
 - 6.5 Reset Timing Characteristics 20
- 7. LCD Module Out-Going Quality Level 22**
 - 7.1 VISUAL & FUNCTION INSPECTION STANDARD..... 22
 - 7.1.1 Inspection conditions 22
 - 7.1.2 Definition..... 22
 - 7.1.3 Sampling Plan..... 23
 - 7.1.4 Criteria (Visual) 24
- 8. Reliability Test Result 28**
- 9. Cautions and Handling Precautions 29**
 - 9.1 Handling and Operating the Module..... 29
 - 9.2 Storage and Transportation. 29

*** Description**

This is a color active matrix TFT (Thin Film Transistor) LCD (liquid crystal display) that uses amorphous silicon TFT as a switching device. This module is composed of a transfective type TFT-LCD Panel, driver circuit, back-light unit. The resolution of a 2.4'TFT-LCD contains 240X320 pixels, and can display up to 262K colors.

*** Features**

General Information Items	Specification	Unit	Note
	Main Panel		
Display area(AA)	36.72(H) *48.96(V) (2.4inch)	mm	-
Driver element	TFT active matrix	-	-
Display colors	262K	colors	-
Number of pixels	240(RGB)*320	dots	-
TFT Pixel arrangement	RGB vertical stripe	-	-
Pixel pitch	0.153 (H) x 0.153 (V)	mm	-
Viewing angle	6:00	o'clock	-
TFT Controller IC	ST7789T3-G4-1	-	-
LCM Interface	8/9/16/18Bit MCU 3/4SPI+16/18Bit RGB 3-line/4-line Serial	-	-
Display mode	Transflective /Normally White	-	-
Operating temperature	-20~+70	°C	-
Storage temperature	-30~+80	°C	-

*** Mechanical Information**

Item		Min.	Typ.	Max.	Unit	Note
Module size	Horizontal(H)		42.92		mm	-
	Vertical(V)		60.26		mm	-
	Depth(D)		2.46		mm	-
Weight			12		g	-

1. Block Diagram

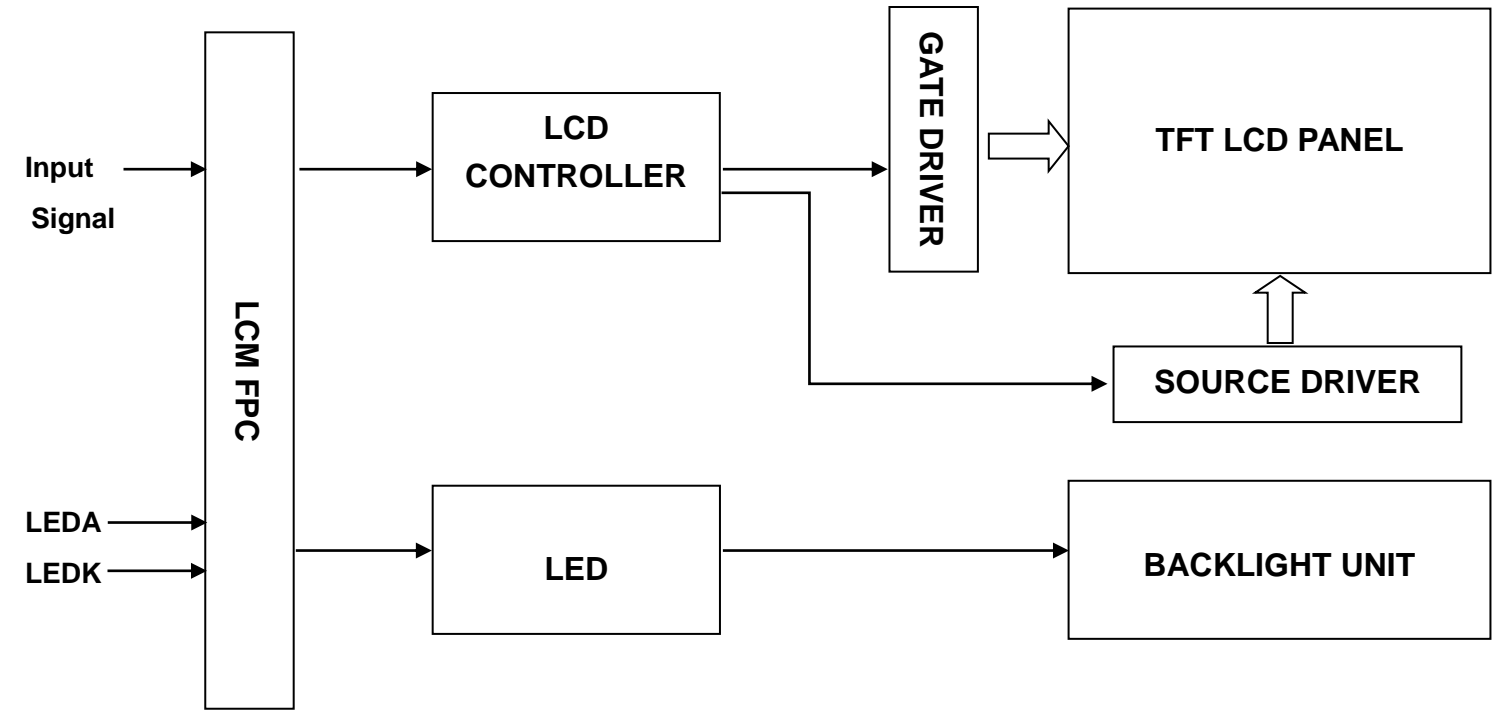

2. Outline dimension

NO.	Pin Name
1	XR(INC)
2	YR(INC)
3	AR(INC)
4	YU(INC)
5	GND
6	GND
7	VCC
8	VCC
9	IOVCC
10	SDD
11	DB17
12	DB16
13	DB15
14	DB14
15	DB13
16	DB12
17	DB11
18	DB10
19	DB09
20	DB08
21	DB07
22	DB06
23	DB05
24	DB04
25	DB03
26	DB02
27	DB01
28	DB0
29	DIN(SDA)
30	PCLK
31	DE
32	HSYNC
33	VSYNC
34	RD
35	WR(SPI-RS)
36	RS(SPI-SCL)
37	CS
38	RESET
39	IM0
40	IM1
41	IM2
42	NC
43	LEDA
44	NC
45	LEDB

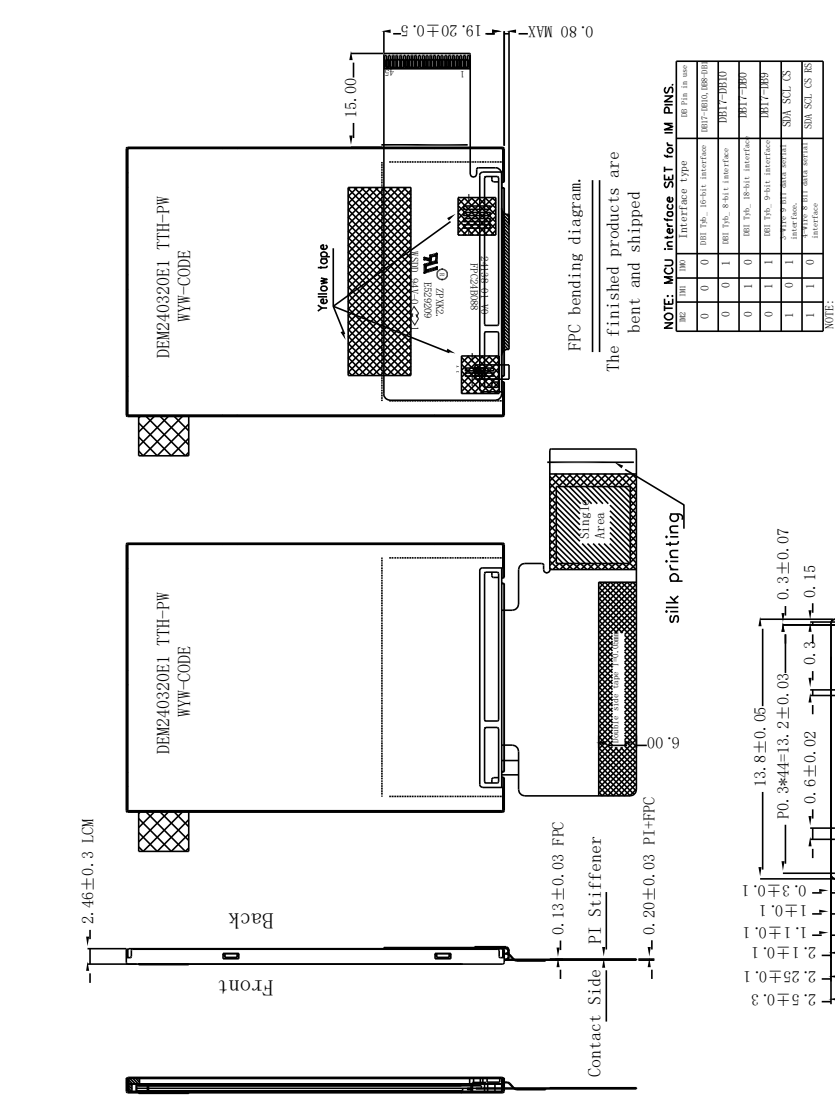

NOTE: MCU interface SET for IM PINS.

IM	IM0	IM1	IM2	Interface Type	SP Pin in use
0	0	0	0	100 Tps, 18-bit interface	IM0-IM0, IM0-IM0
0	0	1	0	100 Tps, 8-bit interface	IM17-IM10
0	1	0	0	100 Tps, 18-bit interface	IM17-IM0
0	1	1	0	100 Tps, 9-bit interface	IM17-IM0
1	0	1	1	100 Tps, 9-bit interface	IM0-SCL, CS
1	1	1	0	100 Tps, 9-bit interface	IM0-SCL, CS

NOTE:
 1. If not use PIN, fix to the GND, IOVCC or VCC.
 2. If use RGB mode must select serial interface.

- NOTE:
1. DISPLAY TYPE: 2.41", TFT-LCD, 262K COLORS
 2. DISPLAY MODE: NORMALLY WHITE, TN, TRANSPARENT
 3. VIEWING DIRECTION: 6 O' Clock
 4. LCM DRIVER IC: ST7789T3-G4-1 (COG)
LCM Interface: 8/9/16/18BIT MCU
3/4SPI+16/18BIT RGB
 5. VDD: 3.3V (TYP.), IOVCC: 1.8-3.3V
 6. OPERATING TEMP: -20° C TO 70° C
STORAGE TEMP: -30° C TO 80° C
 7. BACK LIGHT: LED WHITE, 6 LED, 20mA, 16.2V~19.8V
 8. RoHS COMPLIANT.

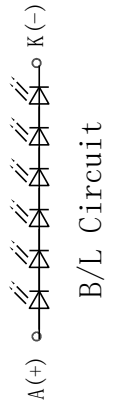

3. Input terminal Pin Assignment

NO.	SYMBOL	DISCRIPTION	I/O
1	NC	--	--
2	NC	--	--
3	NC	--	--
4	NC	--	--
5	GND	Ground.	P
6	GND	Ground.	P
7	VCC	Supply voltage(3.3V).	I
8	VCC	Supply voltage(3.3V).	I
9	IOVCC	Power Supply for I/O System.	I
10	SDO	SPI interface output pin. -The data is output on the falling edge of the SCL signal. -If not used, let this pin open.	O
11-28	DB17-DB0	18-bit parallel bi-directional data bus for MCU system and RGB i nterface mode. Fix to GND level when not in use	I/O
29	DIN(SDA)	Serial input signal. The data is latched on the rising edge of the SCL signal. fix this pin at IOVCC or GND when not in use.	I/O
30	PCLK	Dot clock signal for RGB interface operation. Fix this pin at IOVCC or GND when not in use.	I
31	DE	Data enable signal for RGB interface operation. fix this pin at IOVCC or GND when not in use.	I
32	HSYNC	Line synchronizing signal for RGB interface operation. fix this pin at IOVCC or GND when not in use.	I
33	VSYNC	Frame synchronizing signal for RGB interface operation. fix this pin at IOVCC or GND when not in use.	I
34	RD	Read enable in 8080 MCU parallel interface. -If not used, please fix this pin at IOVCC or DGND.	I
35	WR(SPI-RS)	-Write enable in MCU parallel interface. - Display data/command selection pin in 4-line serial interface. - Second Data lane in 2 data lane serial interface. -If not used, please fix this pin at IOVCC or DGND.	I
36	RS(SPI-SCL)	-Display data/command selection pin in parallel interface.	I

		-This pin is used to be serial interface clock. RS='1': display data or parameter. RS='0': command data. -If not used, please fix this pin at IOVCC or DGND.	
37	CS	Chip select input pin ("Low" enable). fix this pin at IOVCC or GND when not in use.	I
38	RESET	This signal will reset the device and must be applied to properly initialize the chip.	I
39	IM0	18-bit parallel bi-directional data bus for MCU system and RGB interface mode. Fix to GND level when not in use	I
40	IM1		
41	IM2		
42	NC	--	--
43	LEDA	Anode pin of backlight	P
44	NC	--	--
45	LEDK	Cathode pin OF backlight	P

4. LCD Optical Characteristics

4.1 Optical specification (Reflective)

Item	Symbol	Condition	Min.	Typ.	Max.	Unit.	Note
White Reflectance (with Polarizer)	R _w (%)	Θ=0 Normal viewing angle	--	17.54	--	%	
Contrast Ratio	CR		--	15	--		(1)(2)
Response time	Rising		T _{R+T_F}	--	5	7	msec
	Falling	--					
Color Gamut	S(%)		--	13.79	--	%	
Color Filter Chromaticity	White	W _X	--	0.336	--		(1)(4)
		W _Y	--	0.342	--		CA-310
Viewing angle	Hor.	Θ _L	--	55	--	--	(1)(4)
		Θ _R	--	55	--		
	Ver.	Θ _U	--	60	--		
		Θ _D	--	60	--		

4.2 Optical specification (Transmittance)

Item	Symbol	Condition	Min.	Typ.	Max.	Unit.	Note
White Transmittance (with Polarizer)	R _w (%)	Θ=0 Normal viewing angle	--	13.51		%	
Contrast Ratio	CR		60	80	--		(1)(2)
Response time	Rising		T _{R+T_F}	--	6	8	msec
	Falling	--					
Color Gamut	S(%)		--	27	--	%	
Color Filter Chromaticity	White	W _X	-0.04	0.325	+0.04		(1)(4) CA-310
		W _Y		0.351			
	Red	R _X		0.474			
		R _Y		0.291			
	Green	G _X		0.334			
		G _Y		0.480			
	Blue	B _X		0.175			
		B _Y		0.084			
Viewing angle	Hor.	Θ _L	--	60	--		(1)(4)
		Θ _R	--	60	--		
	Ver.	Θ _U	--	60	--		
		Θ _D	--	60	--		
Option View Direction	3 O'clock						

*The data comes from the LCD specification.

Measuring Condition

Measuring surrounding : dark rooms

Ambient temperature : 25±2°C

15min. warm-up time.

Measuring Equipment

FPM520 of Westar Display technologies, INC., which utilized SR-3 for Chromaticity and BM-5A for other optical characteristics.

Note (1): Definition of Viewing Angle :

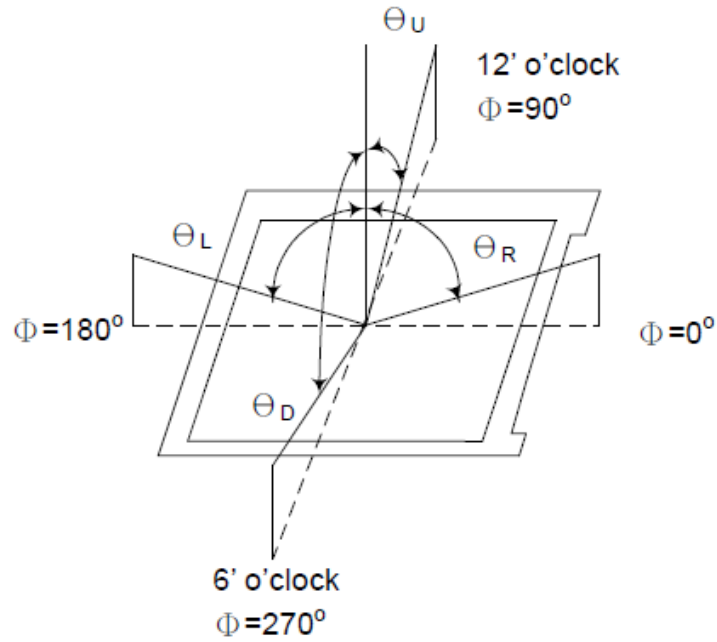

Note (2): Definition of Contrast Ratio(CR) :measured at the center point of panel

$$CR = \frac{\text{Luminance with all pixels white}}{\text{Luminance with all pixels black}}$$

Note (3): Response Time

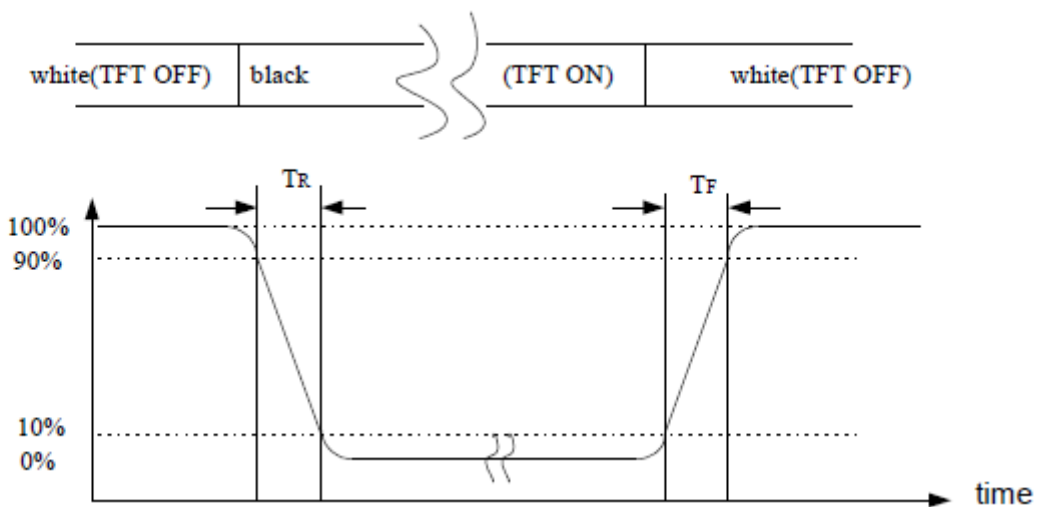

Note (4): Definition of optical measurement setup

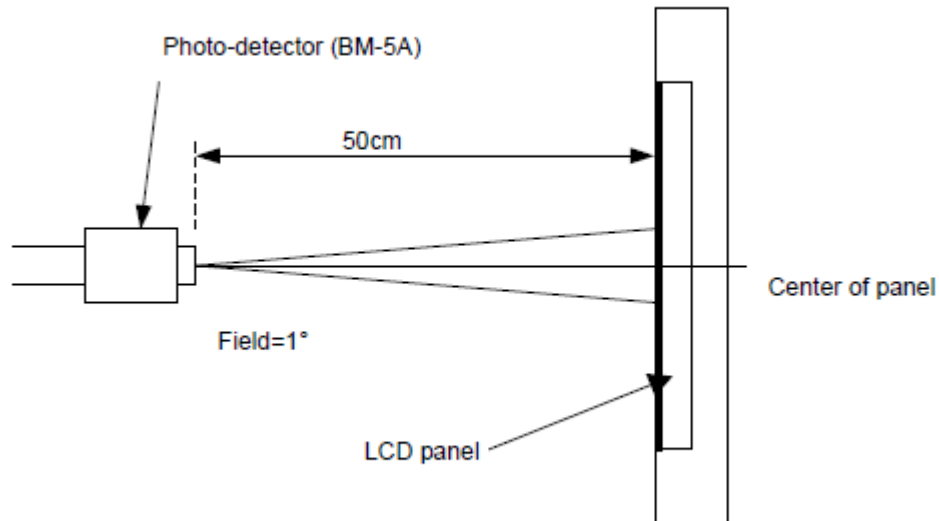

5. Electrical Characteristics

5.1 Absolute Maximum Rating (Ta=25 VSS=0V)

Characteristics	Symbol	Min.	Max.	Unit
Digital Supply Voltage	VCC	-0.3	4.6	V
Supply Voltage (Logic)	IOVCC	-0.3	4.6	
Operating temperature	T _{OP}	-20	+70	°C
Storage temperature	T _{ST}	-30	+80	°C

NOTE: If the absolute maximum rating of even is one of the above parameters is exceeded even momentarily, the quality of the product may be degraded. Absolute maximum ratings, therefore, specify the values exceeding which the product may be physically damaged. Be sure to use the product within the range of the absolute maximum ratings.

5.2 DC Electrical Characteristics

Characteristics	Symbol	Min.	Typ.	Max.	Unit	Note
Digital Supply Voltage	VCC	2.4	3.3	3.6	V	
Supply Voltage (Logic)	IOVCC	1.65	1.8	3.3	V	
Normal mode Current consumption	IDD	--	5	10	mA	
Level input voltage	V _{IH}	0.7 Iovcc		Iovcc	V	
	V _{IL}	GND		0.3Iovcc	V	
Level output voltage	V _{OH}	0.8 Iovcc		Iovcc	V	
	V _{OL}	GND		0.2 Iovcc	V	

5.3 LED Backlight Characteristics

The back-light system is edge-lighting type with 6 chips White LED

Item	Symbol	Min.	Typ.	Max.	Unit	Note
Forward Current	I _F	--	20	--	mA	Constant current
Forward Voltage	V _F	16.8	17.25	19.8	V	
LCM Luminance (I _F =80mA)	L _v	300	350	--	cd/m ²	Note3
LED life time	Hr	50000	--	--	Hour	Note1,2
Uniformity	AVg	80	--	--	%	Note3

Note 1: LED life time (Hr) can be defined as the time in which it continues to operate under the condition:

T_a=25±3 °C, typical IL value indicated in the above table until the brightness becomes less than 50%.

Note 2: The "LED life time" is defined as the module brightness decrease to 50% original brightness at

T_a=25°C and I_L=20mA. The LED lifetime could be decreased if operating I_L is larger than 20mA. The constant current driving method is suggested.

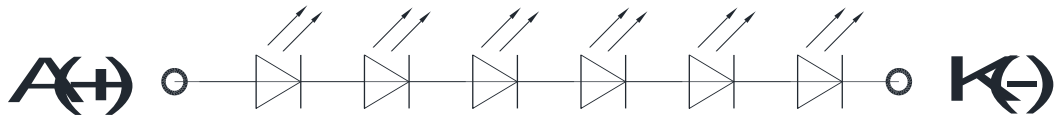

LED(B) CIRCUIT

NOTE 3: Luminance Uniformity of these 9 points is defined as below:

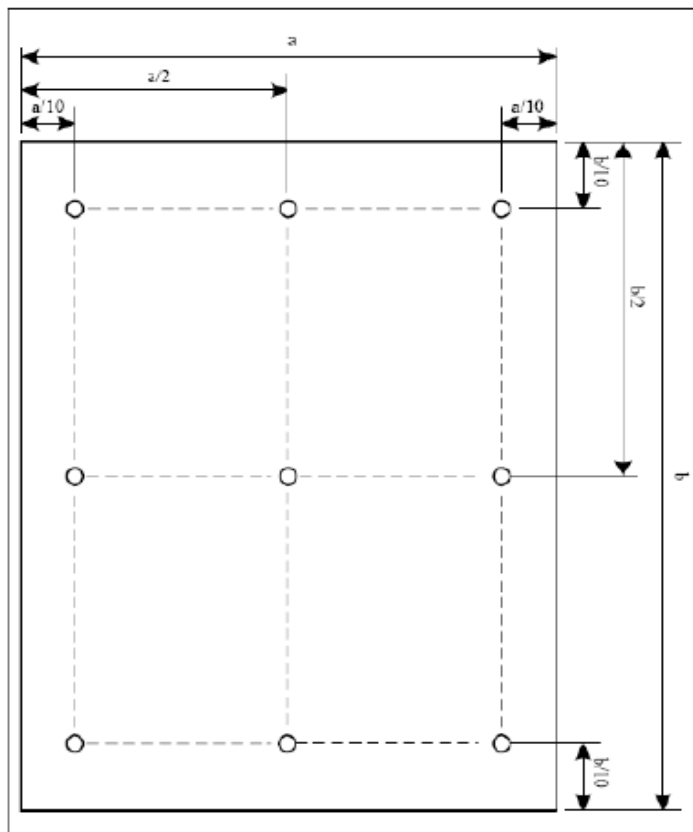

$$\text{Uniformity} = \frac{\text{minimum luminance in 9 points (1-9)}}{\text{maximum luminance in 9 points (1-9)}}$$

$$\text{Luminance} = \frac{\text{Total Luminance of 9 points}}{9}$$

6. AC Characteristic

6.1 8080 Series MCU Parallel Interface Characteristics: 18/16/9/8-bit Bus

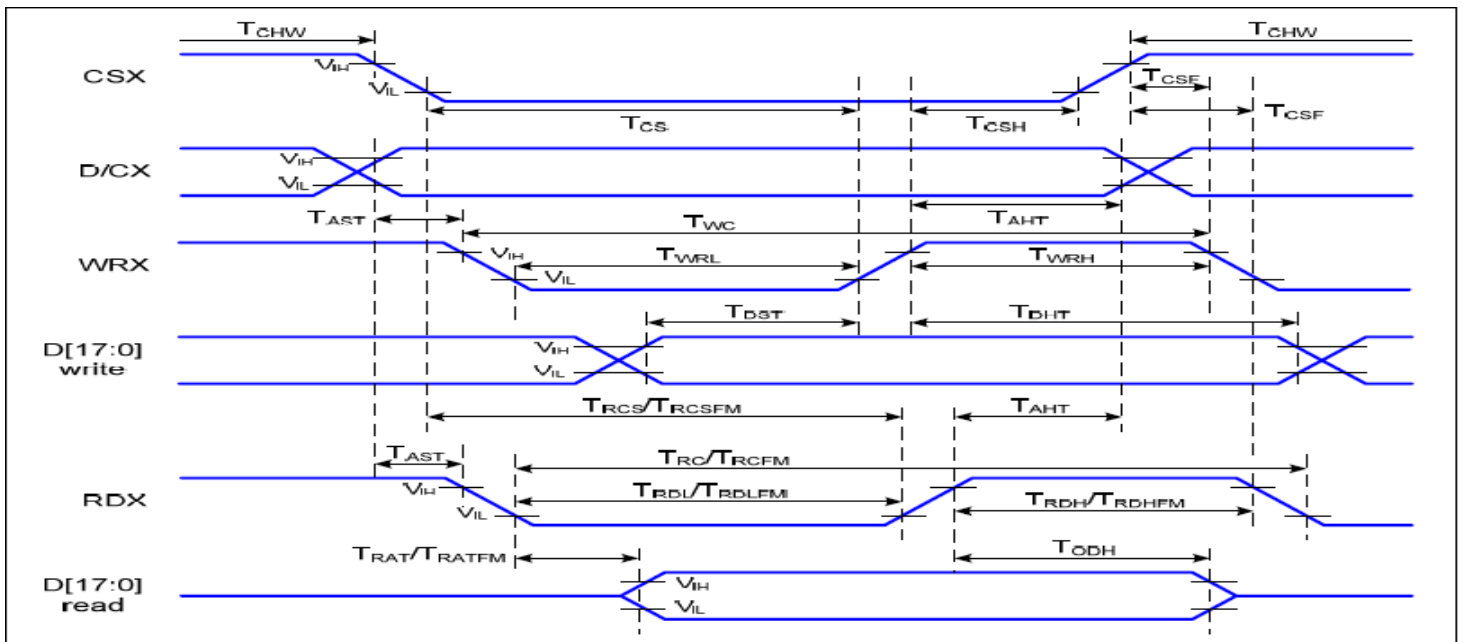

VDDI=1.65 to 3.3V, VDD=2.4 to 3.3V, AGND=DGND=0V, Ta=25°C

Signal	Symbol	Parameter	Min	Max	Unit	Description
D/CX	T _{AST}	Address setup time	0		ns	-
	T _{AHT}	Address hold time (Write/Read)	10		ns	
CSX	T _{CHW}	Chip select "H" pulse width	0		ns	-
	T _{CS}	Chip select setup time (Write)	15		ns	
	T _{RCS}	Chip select setup time (Read ID)	45		ns	
	T _{RCSFM}	Chip select setup time (Read FM)	355		ns	
	T _{CSF}	Chip select wait time (Write/Read)	10		ns	
	T _{CSH}	Chip select hold time	10		ns	
WRX	T _{WC}	Write cycle	66		ns	-
	T _{WRH}	Control pulse "H" duration	15		ns	
	T _{WRL}	Control pulse "L" duration	15		ns	
RDX (ID)	T _{RC}	Read cycle (ID)	160		ns	When read ID data
	T _{RDH}	Control pulse "H" duration (ID)	90		ns	
	T _{RDL}	Control pulse "L" duration (ID)	45		ns	
RDX (FM)	T _{RCFM}	Read cycle (FM)	450		ns	When read from frame memory
	T _{RDHFM}	Control pulse "H" duration (FM)	90		ns	
	T _{RDLFM}	Control pulse "L" duration (FM)	355		ns	
D[17:0]	T _{DST}	Data setup time	10		ns	For CL=30pF

T_{DHT}	Data hold time	10		ns
T_{RAT}	Read access time (ID)		40	ns
T_{RATFM}	Read access time (FM)		340	ns
T_{ODH}	Output disable time	20	80	ns

Table 4 8080 Parallel Interface Characteristics

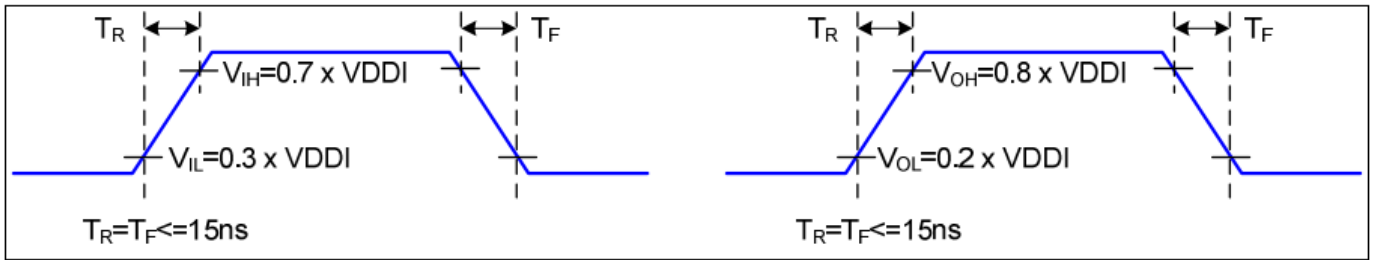

Figure 2 Rising and Falling Timing for I/O Signal

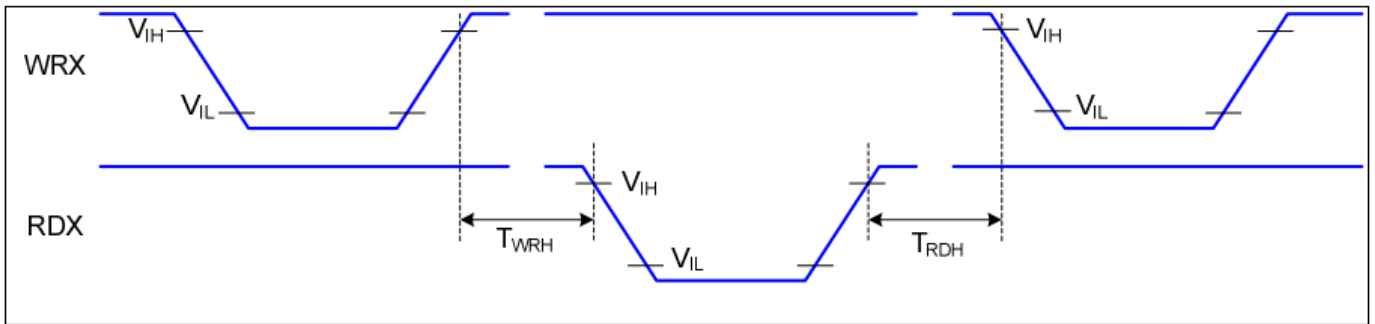

Figure 3 Write-to-Read and Read-to-Write Timing

Note: The rising time and falling time (T_r , T_f) of input signal and fall time are specified at 15 ns or less. Logic high and low levels are specified as 30% and 70% of VDDI for Input signals.

6.2 Serial Interface Characteristics (3-line serial)

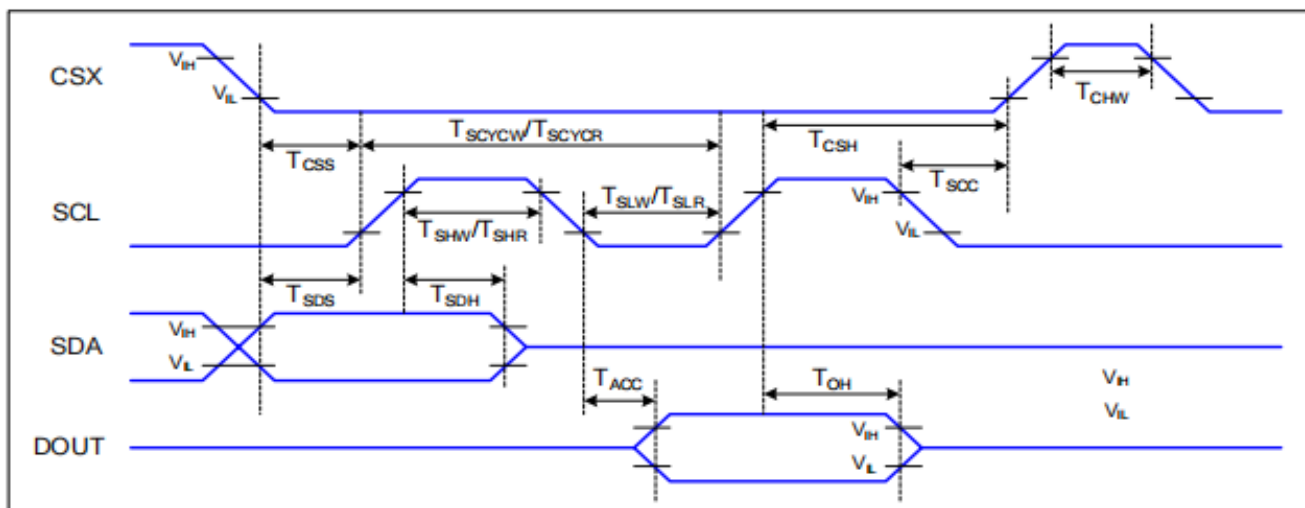

Figure 4 3-line serial Interface Timing Characteristics

VDDI=1.65 to 3.3V, VDD=2.4 to 3.3V, AGND=DGND=0V, Ta=25°C

Signal	Symbol	Parameter	Min	Max	Unit	Description
CSX	T _{css}	Chip select setup time (write)	15		ns	
	T _{csH}	Chip select hold time (write)	15		ns	
	T _{css}	Chip select setup time (read)	60		ns	
	T _{scc}	Chip select hold time (read)	65		ns	
	T _{chwh}	Chip select "H" pulse width	40		ns	
SCL	T _{scycw}	Serial clock cycle (Write)	16		ns	
	T _{shw}	SCL "H" pulse width (Write)	7		ns	
	T _{slw}	SCL "L" pulse width (Write)	7		ns	
	T _{scycr}	Serial clock cycle (Read)	150		ns	
	T _{shr}	SCL "H" pulse width (Read)	60		ns	
	T _{slr}	SCL "L" pulse width (Read)	60		ns	
SDA (DIN)	T _{sdS}	Data setup time	7		ns	
	T _{sdH}	Data hold time	7		ns	
DOUT	T _{acc}	Access time	10	50	ns	For maximum CL=30pF
	T _{oh}	Output disable time	15	50	ns	For minimum CL=8pF

Table 5 3-line serial Interface Characteristics

Note 1 : The rising time and falling time (Tr, Tf) of input signal are specified at 15 ns or less. Logic high and low levels are specified as 30% and 70% of VDDI for Input signals

Note2: In the read sequence of serial interface, the 500nsec delay time is needed between read command and first read clock..

6.3 Serial Interface Characteristics (4-line serial)

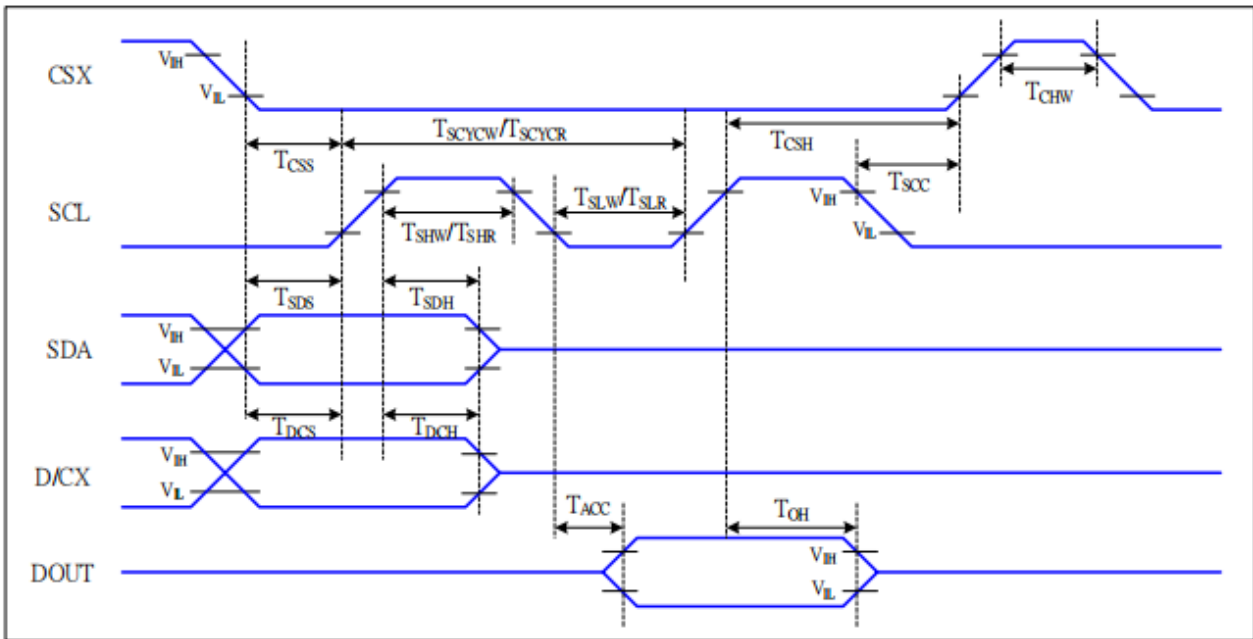

Figure 5 4-line serial Interface Timing Characteristics

VDDI=1.65 to 3.3V, VDD=2.4 to 3.3V, AGND=DGND=0V, Ta=25°C

Signal	Symbol	Parameter	MIN	MAX	Unit	Description
CSX	T _{css}	Chip select setup time (write)	15		ns	
	T _{csh}	Chip select hold time (write)	15		ns	
	T _{css}	Chip select setup time (read)	60		ns	
	T _{scc}	Chip select hold time (read)	65		ns	
	T _{chw}	Chip select "H" pulse width	40		ns	
SCL	T _{scyww}	Serial clock cycle (Write)	16		ns	-write command & data ram
	T _{shw}	SCL "H" pulse width (Write)	7		ns	
	T _{slw}	SCL "L" pulse width (Write)	7		ns	
	T _{scywr}	Serial clock cycle (Read)	150		ns	-read command & data ram
	T _{shr}	SCL "H" pulse width (Read)	60		ns	
	T _{slr}	SCL "L" pulse width (Read)	60		ns	
D/CX	T _{dcs}	D/CX setup time	10		ns	
	T _{dch}	D/CX hold time	10		ns	
SDA (DIN)	T _{sdh}	Data setup time	7		ns	
	T _{sdh}	Data hold time	7		ns	
DOUT	T _{acc}	Access time	10	50	ns	For maximum CL=30pF
	T _{oh}	Output disable time	15	50	ns	For minimum CL=8pF

Table 6 4-line serial Interface Characteristics

Note1 : The rising time and falling time (T_r , T_f) of input signal are specified at 15 ns or less. Logic high and low levels are specified as 30% and 70% of VDDI for Input signals

Note2: In the read sequence of serial interface, the 500nsec delay time is needed between read command and first read clock..

6.4 RGB Interface Characteristics

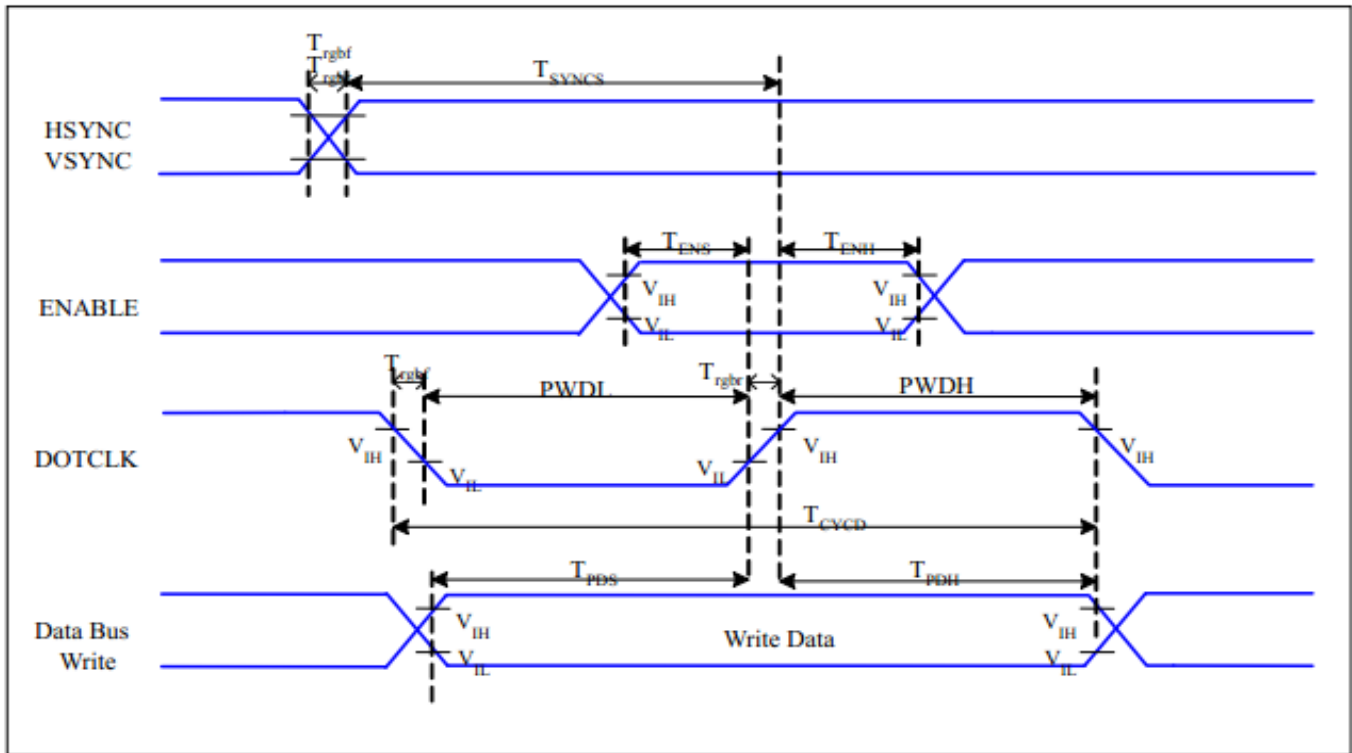

Figure 6 RGB Interface Timing Characteristics

VDDI=1.65 to 3.3V, VDD=2.4 to 3.3V, AGND=DGND=0V, $T_a=25^\circ C$

Signal	Symbol	Parameter	MIN	MAX	Unit	Description
HSYNC, VSYNC	T_{SYNCS}	VSYNC, HSYNC Setup Time	30	-	ns	
ENABLE	T_{ENS}	Enable Setup Time	25	-	ns	
	T_{ENH}	Enable Hold Time	25	-	ns	
DOTCLK	PWDH	DOTCLK High-level Pulse Width	60	-	ns	
	PWDL	DOTCLK Low-level Pulse Width	60	-	ns	
	T_{CYCD}	DOTCLK Cycle Time	120	-	ns	
	T_{rghr} , T_{rghf}	DOTCLK Rise/Fall time	-	20	ns	
DB	T_{PDS}	PD Data Setup Time	50	-	ns	
	T_{PDH}	PD Data Hold Time	50	-	ns	

Table 7 18/16 Bits RGB Interface Timing Characteristics

Signal	Symbol	Parameter	MIN	MAX	Unit	Description
HSYNC, VSYNC	T _{SYNCS}	VSYNC, HSYNC Setup Time	35	-	ns	
ENABLE	T _{ENS}	Enable Setup Time	35	-	ns	

	T _{ENH}	Enable Hold Time	35	-	ns	
DOTCLK	PWDH	DOTCLK High-level Pulse Width	35	-	ns	
	PWDL	DOTCLK Low-level Pulse Width	35	-	ns	
	T _{CYCD}	DOTCLK Cycle Time	80	-	ns	
	Trghr, Trghf	DOTCLK Rise/Fall time	-	10	ns	
DB	T _{PDS}	PD Data Setup Time	35	-	ns	
	T _{PDH}	PD Data Hold Time	35	-	ns	

Table 8 6 Bits RGB Interface Timing Characteristics

6.5 Reset Timing Characteristics

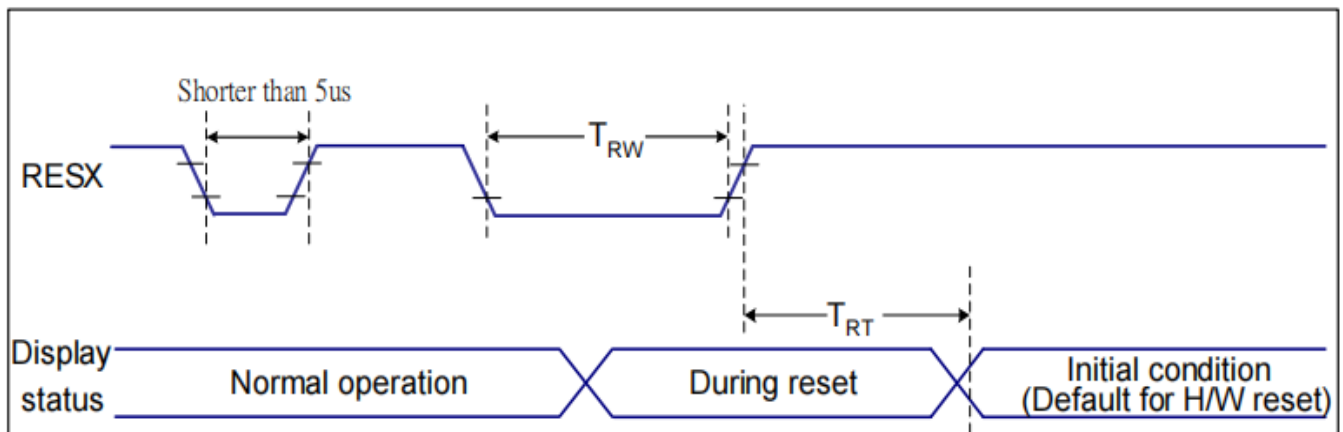

Figure 7 Reset Timing

VDDI=1.65 to 3.3V, VDD=2.4 to 3.3V, AGND=DGND=0V, Ta=25°C

Related Pins	Symbol	Parameter	MIN	MAX	Unit
RESX	TRW	Reset pulse duration	10	-	us
	TRT	Reset cancel	-	5 (Note 1, 5)	ms
			120 (Note 1, 6, 7)	ms	

Table 9 Reset Timing

Notes:

1. The reset cancel includes also required time for loading ID bytes, VCOM setting and other settings from NVM (or similar device) to registers. This loading is done every time when there is HW reset cancel time (tRT) within 5 ms after a rising edge of RESX.

2. Spike due to an electrostatic discharge on RESX line does not cause irregular system reset according to the table below:

RESX Pulse	Action
Shorter than 5us	Reset Rejected
Longer than 9us	Reset
Between 5us and 9us	Reset starts

3. During the Resetting period, the display will be blanked (The display is entering blanking sequence, which maximum time is 120 ms, when Reset Starts in Sleep Out –mode. The display remains the blank state in Sleep In –mode.) and then return to Default condition for Hardware Reset.

4. Spike Rejection also applies during a valid reset pulse as shown below:

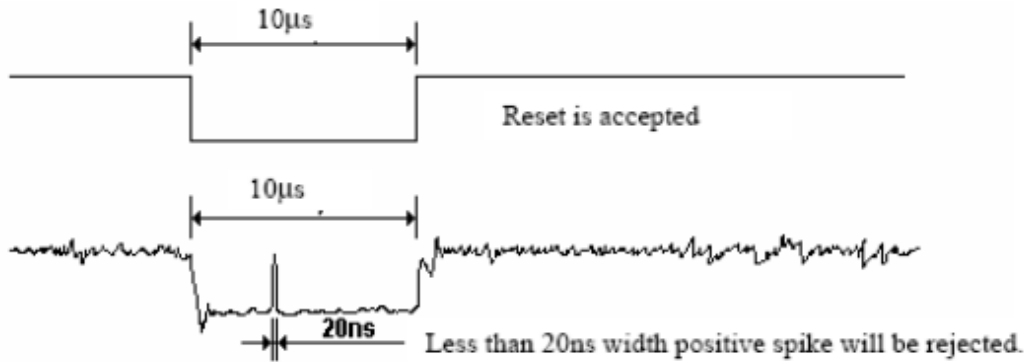

5. When Reset applied during Sleep In Mode.

6. When Reset applied during Sleep Out Mode.

7. It is necessary to wait 5msec after releasing RESX before sending commands. Also Sleep Out command cannot be sent for 120msec.

7. LCD Module Out-Going Quality Level

7.1 VISUAL & FUNCTION INSPECTION STANDARD

7.1.1 Inspection conditions

Inspection performed under the following conditions is recommended.

Temperature : $25\pm 5^{\circ}\text{C}$

Humidity : $65\%\pm 10\%\text{RH}$

Viewing Angle : Normal viewing Angle.

Illumination: Single fluorescent lamp (300 to 700Lux)

Viewing distance:30-50cm

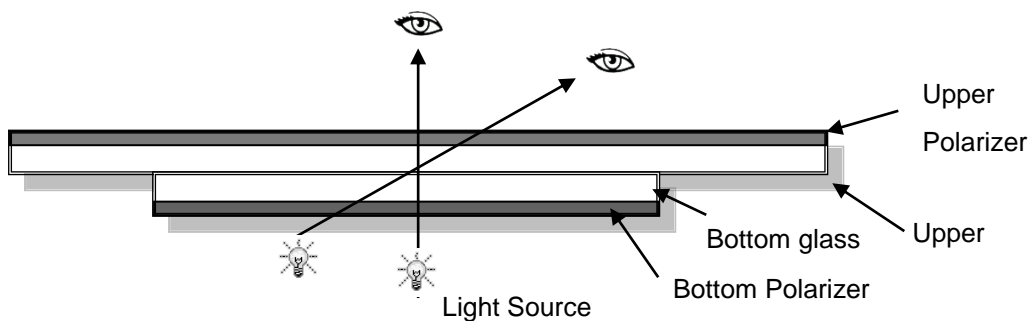

7.1.2 Definition

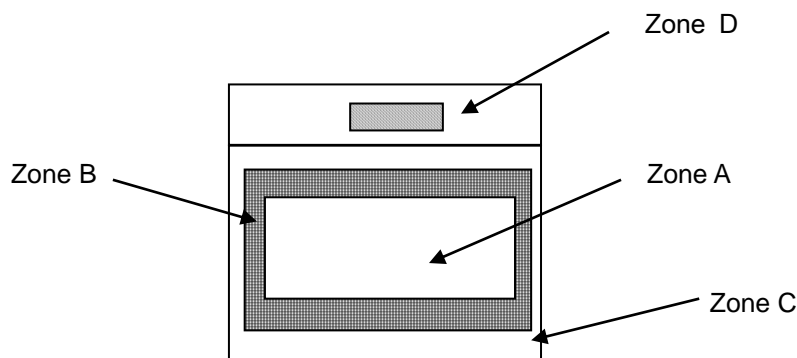

Zone A : Effective Viewing Area(Character or Digit can be seen)

Zone B : Viewing Area except Zone A

Zone C : Outside (Zone A+Zone B) which can not be seen after assembly by customer

Zone D : IC Bonding Area

Note:As a general rule ,visual defects in Zone C can be ignored when it doesn't effect product function or appearance after assembly by customer

7.1.3 Sampling Plan

According to GB/T 2828-2012 ; , normal inspection, Class II

AQL:

Major defect	Minor defect
0.65	1.5

LCD: Liquid Crystal Display , LCM: Liquid Crystal Module,

No	Items to be inspected	Criteria	Classification of defects
1	Functional defects	1) No display, Open or miss line 2) Display abnormally, Short 3) Backlight no lighting, abnormal lighting. etc...	Major
2	Missing	Missing components and etc...	
3	Outline dimension	Overall outline dimension beyond the drawing is not allowed, deformation and etc...	
4	Color tone	Color unevenness, refer to limited sample	Minor
5	Spot/Line defect	Light dot, Dim spot, (Note1) Polarizer Air Bubble, Polarizer accidented spot and etc.	
6	Soldering appearance	Good soldering , Peeling off is not allowed and etc.	
7	LCD/Polarizer	Black/White spot/line, scratch, crack, etc.	



Note1: a) Light dot: Dots appear bright and unchanged in size in which LCD panel is displaying under black pattern.

b) Dim dot: Dots appear dark and unchanged in size in which LCD panel is displaying under pure red, green, blue picture.

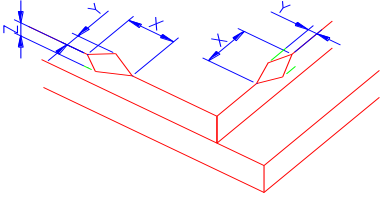
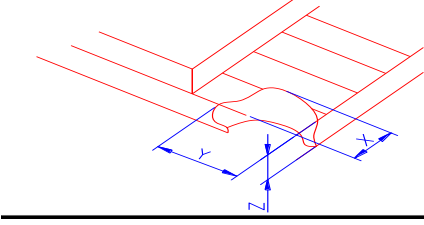
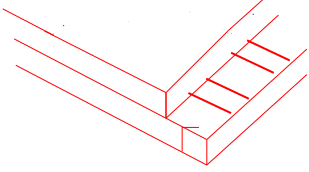
7.1.4 Criteria (Visual)

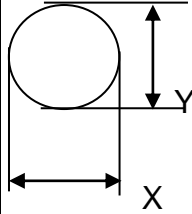
Number	Items	Criteria(mm)						
1.0 LCD Crack/Broken NOTE: X: Length Y: Width Z: Height L: Length of ITO, T: Height of LCD	(1) The edge of LCD broken	 <table border="1" data-bbox="756 613 1455 761"> <thead> <tr> <th>X</th> <th>Y</th> <th>Z</th> </tr> </thead> <tbody> <tr> <td>≤3.0mm</td> <td><Inner border line of the seal</td> <td>≤T</td> </tr> </tbody> </table>	X	Y	Z	≤3.0mm	<Inner border line of the seal	≤T
	X	Y	Z					
	≤3.0mm	<Inner border line of the seal	≤T					
(2)LCD corner broken	 <table border="1" data-bbox="836 1070 1375 1169"> <thead> <tr> <th>X</th> <th>Y</th> <th>Z</th> </tr> </thead> <tbody> <tr> <td>≤3.0mm</td> <td>≤L</td> <td>≤T</td> </tr> </tbody> </table>	X	Y	Z	≤3.0mm	≤L	≤T	
X	Y	Z						
≤3.0mm	≤L	≤T						
(3) LCD crack	 <p style="text-align: center;">Crack Not allowed</p>							

2.0	Spot defect	<p>① light dot (black/white spot , pinhole, stain, etc.)</p> <table border="1" style="width: 100%; border-collapse: collapse;"> <thead> <tr> <th rowspan="2" style="text-align: center;">Zone Size (mm)</th> <th colspan="3" style="text-align: center;">Acceptable Qty</th> </tr> <tr> <th style="text-align: center;">A</th> <th style="text-align: center;">B</th> <th style="text-align: center;">C</th> </tr> </thead> <tbody> <tr> <td style="text-align: center;">$\Phi \leq 0.15$</td> <td colspan="3" style="text-align: center;">Ignore</td> </tr> <tr> <td style="text-align: center;">$0.15 < \Phi \leq 0.25$</td> <td colspan="3" style="text-align: center;">3(distance ≥ 6mm)</td> </tr> <tr> <td style="text-align: center;">$0.25 < \Phi \leq 0.4$</td> <td colspan="3" style="text-align: center;">2(distance ≥ 6mm)</td> </tr> <tr> <td style="text-align: center;">$\Phi > 0.4$</td> <td colspan="3" style="text-align: center;">0</td> </tr> </tbody> </table> <p>② Dim spot (light leakage, dent, dark spot, etc)</p> <table border="1" style="width: 100%; border-collapse: collapse;"> <thead> <tr> <th rowspan="2" style="text-align: center;">Zone Size (mm)</th> <th colspan="3" style="text-align: center;">Acceptable Qty</th> </tr> <tr> <th style="text-align: center;">A</th> <th style="text-align: center;">B</th> <th style="text-align: center;">C</th> </tr> </thead> <tbody> <tr> <td style="text-align: center;">$\Phi \leq 0.15$</td> <td colspan="3" style="text-align: center;">Ignore</td> </tr> <tr> <td style="text-align: center;">$0.15 < \Phi \leq 0.25$</td> <td colspan="3" style="text-align: center;">3(distance ≥ 6mm)</td> </tr> <tr> <td style="text-align: center;">$0.25 < \Phi \leq 0.4$</td> <td colspan="3" style="text-align: center;">2(distance ≥ 6mm)</td> </tr> <tr> <td style="text-align: center;">$\Phi > 0.4$</td> <td colspan="3" style="text-align: center;">0</td> </tr> </tbody> </table> <p>③ Polarizer accidented spot</p> <table border="1" style="width: 100%; border-collapse: collapse;"> <thead> <tr> <th rowspan="2" style="text-align: center;">Zone Size (mm)</th> <th colspan="3" style="text-align: center;">Acceptable Qty</th> </tr> <tr> <th style="text-align: center;">A</th> <th style="text-align: center;">B</th> <th style="text-align: center;">C</th> </tr> </thead> <tbody> <tr> <td style="text-align: center;">$\Phi \leq 0.2$</td> <td colspan="2" style="text-align: center;">Ignore</td> <td rowspan="3" style="text-align: center;">Ignore</td> </tr> <tr> <td style="text-align: center;">$0.2 < \Phi \leq 0.5$</td> <td colspan="2" style="text-align: center;">2(distance ≥ 6mm)</td> </tr> <tr> <td style="text-align: center;">$\Phi > 0.5$</td> <td colspan="2" style="text-align: center;">0</td> </tr> </tbody> </table> <p>④ Polarizer Bubble</p> <table border="1" style="width: 100%; border-collapse: collapse;"> <thead> <tr> <th rowspan="2" style="text-align: center;">Zone Size (mm)</th> <th colspan="3" style="text-align: center;">Acceptable Qty</th> </tr> <tr> <th style="text-align: center;">A</th> <th style="text-align: center;">B</th> <th style="text-align: center;">C</th> </tr> </thead> <tbody> <tr> <td style="text-align: center;">$\Phi \leq 0.2$</td> <td colspan="2" style="text-align: center;">Ignore</td> <td rowspan="3" style="text-align: center;">Ignore</td> </tr> <tr> <td style="text-align: center;">$0.2 < \Phi \leq 0.4$</td> <td colspan="2" style="text-align: center;">3(distance ≥ 6mm)</td> </tr> <tr> <td style="text-align: center;">$\Phi > 0.4$</td> <td colspan="2" style="text-align: center;">0</td> </tr> </tbody> </table>	Zone Size (mm)	Acceptable Qty			A	B	C	$\Phi \leq 0.15$	Ignore			$0.15 < \Phi \leq 0.25$	3(distance ≥ 6 mm)			$0.25 < \Phi \leq 0.4$	2(distance ≥ 6 mm)			$\Phi > 0.4$	0			Zone Size (mm)	Acceptable Qty			A	B	C	$\Phi \leq 0.15$	Ignore			$0.15 < \Phi \leq 0.25$	3(distance ≥ 6 mm)			$0.25 < \Phi \leq 0.4$	2(distance ≥ 6 mm)			$\Phi > 0.4$	0			Zone Size (mm)	Acceptable Qty			A	B	C	$\Phi \leq 0.2$	Ignore		Ignore	$0.2 < \Phi \leq 0.5$	2(distance ≥ 6 mm)		$\Phi > 0.5$	0		Zone Size (mm)	Acceptable Qty			A	B	C	$\Phi \leq 0.2$	Ignore		Ignore	$0.2 < \Phi \leq 0.4$	3(distance ≥ 6 mm)		$\Phi > 0.4$	0	
	Zone Size (mm)			Acceptable Qty																																																																														
			A	B	C																																																																													
	$\Phi \leq 0.15$		Ignore																																																																															
	$0.15 < \Phi \leq 0.25$		3(distance ≥ 6 mm)																																																																															
$0.25 < \Phi \leq 0.4$	2(distance ≥ 6 mm)																																																																																	
$\Phi > 0.4$	0																																																																																	
Zone Size (mm)	Acceptable Qty																																																																																	
	A	B	C																																																																															
$\Phi \leq 0.15$	Ignore																																																																																	
$0.15 < \Phi \leq 0.25$	3(distance ≥ 6 mm)																																																																																	
$0.25 < \Phi \leq 0.4$	2(distance ≥ 6 mm)																																																																																	
$\Phi > 0.4$	0																																																																																	
Zone Size (mm)	Acceptable Qty																																																																																	
	A	B	C																																																																															
$\Phi \leq 0.2$	Ignore		Ignore																																																																															
$0.2 < \Phi \leq 0.5$	2(distance ≥ 6 mm)																																																																																	
$\Phi > 0.5$	0																																																																																	
Zone Size (mm)	Acceptable Qty																																																																																	
	A	B	C																																																																															
$\Phi \leq 0.2$	Ignore		Ignore																																																																															
$0.2 < \Phi \leq 0.4$	3(distance ≥ 6 mm)																																																																																	
$\Phi > 0.4$	0																																																																																	
																																																																																		
$\Phi = (X+Y)/2$																																																																																		

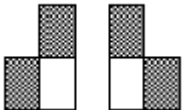
3.0	LCD Pixel defect	<p>Pixel bad points</p> <table border="1" data-bbox="539 250 1497 999"> <thead> <tr> <th data-bbox="539 250 730 304">Item</th> <th data-bbox="730 250 1244 304">Zone A</th> <th data-bbox="1244 250 1497 304">Acceptable Qty</th> </tr> </thead> <tbody> <tr> <td data-bbox="539 304 730 465" rowspan="3">Bright dot</td> <td data-bbox="730 304 1244 358">Random</td> <td data-bbox="1244 304 1497 358">N≤2</td> </tr> <tr> <td data-bbox="730 358 1244 412">2 dots adjacent</td> <td data-bbox="1244 358 1497 412">N≤0</td> </tr> <tr> <td data-bbox="730 412 1244 465">3 dots adjacent</td> <td data-bbox="1244 412 1497 465">N≤0</td> </tr> <tr> <td data-bbox="539 465 730 631" rowspan="3">Dark dot</td> <td data-bbox="730 465 1244 519">Random</td> <td data-bbox="1244 465 1497 519">N≤2</td> </tr> <tr> <td data-bbox="730 519 1244 573">2 dots adjacent</td> <td data-bbox="1244 519 1497 573">N≤0</td> </tr> <tr> <td data-bbox="730 573 1244 631">3 dots adjacent</td> <td data-bbox="1244 573 1497 631">N≤0</td> </tr> <tr> <td data-bbox="539 631 730 945">Distance</td> <td data-bbox="730 631 1244 945"> 1. Minimum Distance Between Bright dots. 2. Minimum Distance Between dark dots 3. Minimum Distance Between dark and bright dot. </td> <td data-bbox="1244 631 1497 945">5mm</td> </tr> <tr> <td colspan="2" data-bbox="539 945 1244 999">Total bright and dark dot</td> <td data-bbox="1244 945 1497 999">N≤4</td> </tr> </tbody> </table> <p data-bbox="539 1008 619 1043">Note:</p> <p data-bbox="539 1061 1481 1151">A) Bright dot: Dots appear bright and unchanged in size in which LCD panel is displaying under black pattern.</p> <p data-bbox="539 1169 1439 1258">B) Dark dot: Dots appear dark and unchanged in size in which LCD panel is displaying under pure red, green, blue picture.</p> <p data-bbox="539 1317 1031 1352">C) 2 dot adjacent = 1 pair = 2 dots</p> <p data-bbox="539 1366 651 1402">Picture:</p> <div data-bbox="667 1451 743 1509" style="display: inline-block; text-align: center;">  </div> <p data-bbox="584 1559 791 1594">2 dot adjacent</p> <div data-bbox="1075 1451 1187 1509" style="display: inline-block; text-align: center;">  </div> <p data-bbox="1027 1559 1235 1594">2 dot adjacent</p> <div data-bbox="676 1621 718 1729" style="display: inline-block; text-align: center;">  </div> <p data-bbox="539 1751 874 1787">2 dot adjacent (vertical)</p> <div data-bbox="1082 1621 1264 1729" style="display: inline-block; text-align: center;">  </div> <p data-bbox="1011 1751 1321 1787">2 dot adjacent (slant)</p>	Item	Zone A	Acceptable Qty	Bright dot	Random	N≤2	2 dots adjacent	N≤0	3 dots adjacent	N≤0	Dark dot	Random	N≤2	2 dots adjacent	N≤0	3 dots adjacent	N≤0	Distance	1. Minimum Distance Between Bright dots. 2. Minimum Distance Between dark dots 3. Minimum Distance Between dark and bright dot.	5mm	Total bright and dark dot		N≤4
Item	Zone A	Acceptable Qty																							
Bright dot	Random	N≤2																							
	2 dots adjacent	N≤0																							
	3 dots adjacent	N≤0																							
Dark dot	Random	N≤2																							
	2 dots adjacent	N≤0																							
	3 dots adjacent	N≤0																							
Distance	1. Minimum Distance Between Bright dots. 2. Minimum Distance Between dark dots 3. Minimum Distance Between dark and bright dot.	5mm																							
Total bright and dark dot		N≤4																							

4.0	Line defect (LCD /Polarizer backlight black/white line, scratch, stain)  W: width, L : length N : Count	<table border="1"> <thead> <tr> <th rowspan="2">Width(mm)</th> <th rowspan="2">Length(m m)</th> <th colspan="3">Acceptable Qty</th> </tr> <tr> <th>A</th> <th>B</th> <th>C</th> </tr> </thead> <tbody> <tr> <td>$\Phi \leq 0.03$</td> <td>Ignore</td> <td colspan="2">Ignore</td> <td rowspan="3">Ignore</td> </tr> <tr> <td>$0.03 < W \leq 0.04$</td> <td>$L \leq 3.0$</td> <td colspan="2">$N \leq 2$</td> </tr> <tr> <td>$0.04 < W \leq 0.05$</td> <td>$L \leq 2.0$</td> <td colspan="2">$N \leq 1$</td> </tr> <tr> <td>$W > 0.05$</td> <td colspan="4">Define as spot defect</td> </tr> </tbody> </table>	Width(mm)	Length(m m)	Acceptable Qty			A	B	C	$\Phi \leq 0.03$	Ignore	Ignore		Ignore	$0.03 < W \leq 0.04$	$L \leq 3.0$	$N \leq 2$		$0.04 < W \leq 0.05$	$L \leq 2.0$	$N \leq 1$		$W > 0.05$	Define as spot defect			
		Width(mm)			Length(m m)	Acceptable Qty																						
			A	B		C																						
		$\Phi \leq 0.03$	Ignore	Ignore		Ignore																						
		$0.03 < W \leq 0.04$	$L \leq 3.0$	$N \leq 2$																								
$0.04 < W \leq 0.05$	$L \leq 2.0$	$N \leq 1$																										
$W > 0.05$	Define as spot defect																											
5.0	Electronic Components SMT.	Not allow missing parts, solderless connection, cold solder joint, mismatch, The positive and negative polarity opposite																										
6.0	Display color& Brightness.	1. Color: Measuring the color coordinates, The measurement standard according to the datasheet or samples. 2. Brightness: Measuring the brightness of White screen, The measurement standard according to the datasheet or Samples.																										
7.0	LCD Mura/Waving/ Hot spot	Not visible through 5% ND filter in 50% gray or judge by limit sample if necessary.																										

Criteria (functional items)

Number	Items	Criteria (mm)
1	No display	Not allowed
2	Missing segment	Not allowed
3	Short	Not allowed
4	Backlight no lighting	Not allowed

8. Reliability Test Result

Item	Condition	Inspection after test
High Temperature Operating	70°C,96H	Inspection after 2~4hours storage at room temperature, the sample shall be free from defects: 1.Air bubble in the LCD; 2.Non-display; 3.Missing segments/line; 4.Glass crack; 5.Current IDD is twice higher than initial value.
Low Temperature Operating	-20°C, 96HRS	
High Temperature Storage	80°C, 96HR	
Low Temperature Storage	-30°C, 96HR	
High Temperature & High Humidity Operating	+60°C, 90% RH ,96 hours.	
Thermal Shock (Non-operation)	-10°C,30 min ↔ +60°C,30 min, Change time:5min 20CYC.	
ESD test	C=150pF, R=330,5points/panel Air:±8KV, 5times; Contact:±6KV, 5 times; (Environment: 15°C ~35°C, 30%~60%).	
Vibration (Non-operation)	Frequency range:10~55Hz, Stroke:1.5mm Sweep:10Hz~55Hz~10Hz 2 hours for each direction of X.Y.Z. (6 hours for total) (Package condition).	
Box Drop Test	1 Corner 3 Edges 6 faces,80cm(MEDIUM BOX)	

Remark:

- 1.The test samples should be applied to only one test item.
- 2.Sample size for each test item is 5~10pcs.
- 3.For Damp Proof Test, Pure water(Resistance > 10MΩ) should be used.
- 4.In case of malfunction defect caused by ESD damage, if it would be recovered to normal state after resetting, it would be judged as a good part.
- 5.Failure Judgment Criterion: Basic Specification, Electrical Characteristic, Mechanical Characteristic, Optical Characteristic.
6. The color fading mura of polarizing filter should not care.

9. Cautions and Handling Precautions

9.1 Handling and Operating the Module

(1) When the module is assembled, it should be attached to the system firmly.

Do not warp or twist the module during assembly work.

(2) Protect the module from physical shock or any force. In addition to damage, this may cause improper operation or damage to the module and back-light unit.

(3) Note that polarizer is very fragile and could be easily damaged. Do not press or scratch the surface.

(4) Do not allow drops of water or chemicals to remain on the display surface.

If you have the droplets for a long time, staining and discoloration may occur.

(5) If the surface of the polarizer is dirty, clean it using some absorbent cotton or soft cloth.

(6) The desirable cleaners are water, IPA (Isopropyl Alcohol) or Hexane.

Do not use ketene type materials (ex. Acetone), Ethyl alcohol, Toluene, Ethyl acid or Methyl chloride. It might permanent damage to the polarizer due to chemical reaction.

(7) If the liquid crystal material leaks from the panel, it should be kept away from the eyes or mouth. In case of contact with hands, legs, or clothes, it must be washed away thoroughly with soap.

(8) Protect the module from static; it may cause damage to the CMOS ICs.

(9) Use finger-stalls with soft gloves in order to keep display clean during the incoming inspection and assembly process.

(10) Do not disassemble the module.

(11) Protection film for polarizer on the module shall be slowly peeled off just before use so that the electrostatic charge can be minimized.

(12) Pins of I/F connector shall not be touched directly with bare hands.

(13) Do not connect, disconnect the module in the "Power ON" condition.

9.2 Storage and Transportation.

(1) Do not leave the panel in high temperature, and high humidity for a long time.

It is highly recommended to store the module with temperature from 0 to 35 °C and relative humidity of less than 70%

(2) Do not store the TFT-LCD module in direct sunlight.

(3) The module shall be stored in a dark place. When storing the modules for a long time, be sure to adopt effective measures for protecting the modules from strong ultraviolet radiation, sunlight, or fluorescent light.

(4) It is recommended that the modules should be stored under a condition where no condensation is allowed. Formation of dewdrops may cause an abnormal operation or a failure of the module.

In particular, the greatest possible care should be taken to prevent any module from being operated where condensation has occurred inside.

(5) This panel has its circuitry FPC on the bottom side and should be handled carefully in order not to be stressed.