

Display Elektronik GmbH

DATA SHEET

TFT MODULE

DEM 800480M1 TTH-PW

5,0“ transfl. TFT

Product Specification

Version: 1

22.01.2025

Contents

1. Block Diagram	5
2. Outline dimension	6
3. Input terminal Pin Assignment	7
4. LCD Optical Characteristics	9
4.1 Optical specification (Reflective)	9
4.2 Optical specification (Transmittance)	10
5. Electrical Characteristics	13
5.1 Absolute Maximum Rating	13
5.2 DC Electrical Characteristics	13
5.3 LED Backlight Characteristics	14
6. AC Characteristics	16
6.1 AC Timing characteristics	16
6.2 Timing Table	17
7. LCD Module Out-Going Quality Level	18
7.1 VISUAL & FUNCTION INSPECTION STANDARD	18
7.1.1 Inspection conditions	18
7.1.2 Definition	18
7.1.3 Sampling Plan	19
7.1.4 Criteria (Visual)	20
8. Reliability Test Result	24
9. Cautions and Handling Precautions	25
9.1 Handling and Operating the Module	25
9.2 Storage and Transportation.	25

*** Description**

This is a color active matrix TFT (Thin Film Transistor) LCD (liquid crystal display) that uses amorphous silicon TFT as a switching device. This model is composed of a transmissive type TFT-LCD Panel, driver circuit, backlight unit. The resolution of a 5.0" TFT-LCD contains 800xRGBx480 Pixels, and can display up to 16.7 Million colors.

*** Features**

General Information Items	Specification	Unit	Note
	Main Panel		
Display Area (AA)	108.00 x 64.80 (5.0 Inch)	mm	-
Driver Element	TFT Active Matrix	-	-
Display Colors	16.7 Million	colors	-
Number of Pixels	800 x RGB x 480	dots	-
Pixel Arrangement	RGB Vertical Stripe	-	-
Pixel Pitch	0.135 x 0.135	mm	-
Viewing Angle	12:00	o'clock	-
Controller IC	HX8264+HX8664 (Himax)	-	-
LCM Interface	16/18/24-BIT-RGB	-	-
Display Mode	Transmissive / Normally White	-	-
Operating Temperature	-20°C ~ +70°C	°C	-
Storage Temperature	-30°C ~ +80°C	°C	-

*** Mechanical Information**

Item		Min.	Typ.	Max.	Unit	Note
Module Size	Horizontal(H)	-	120.70	-	mm	-
	Vertical(V)	-	75.90	-	mm	-
	Depth(D)	-	2,77	-	mm	-
Weight		-	47	-	g	-

1. Block Diagram

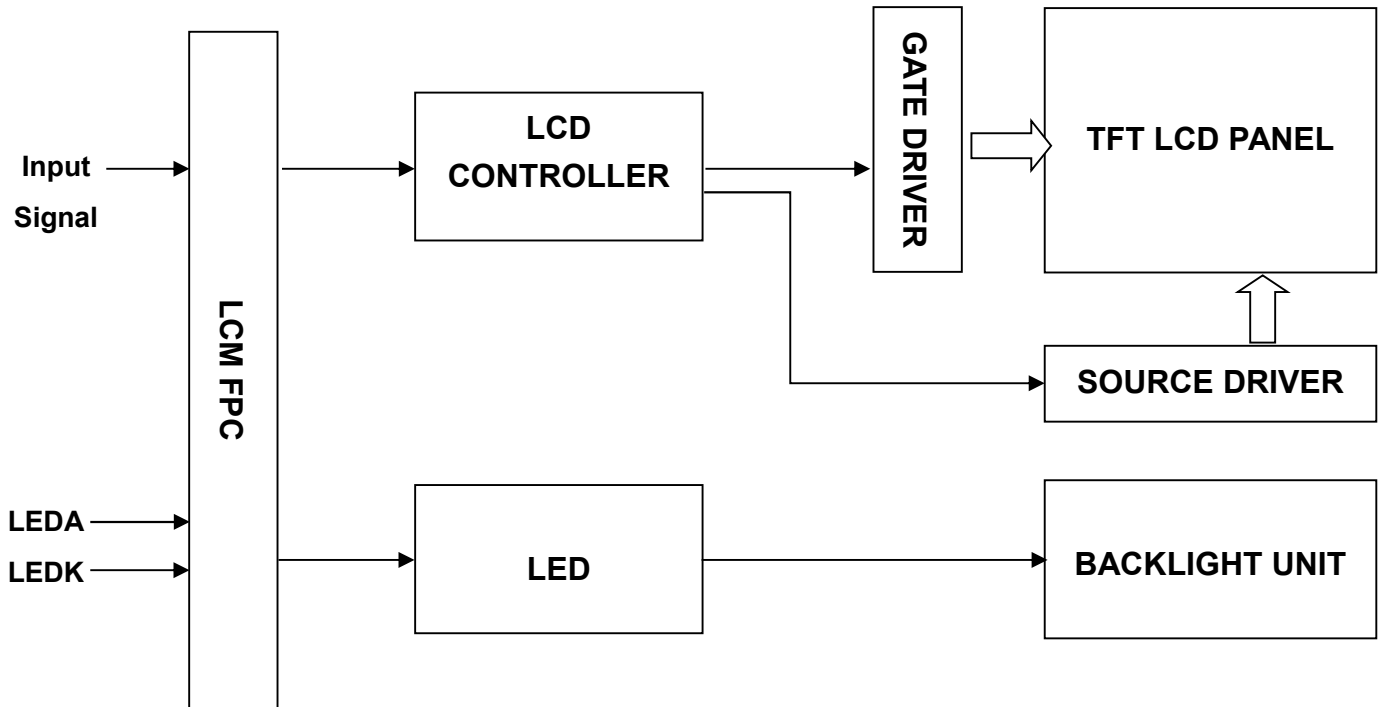

2. Outline Dimension

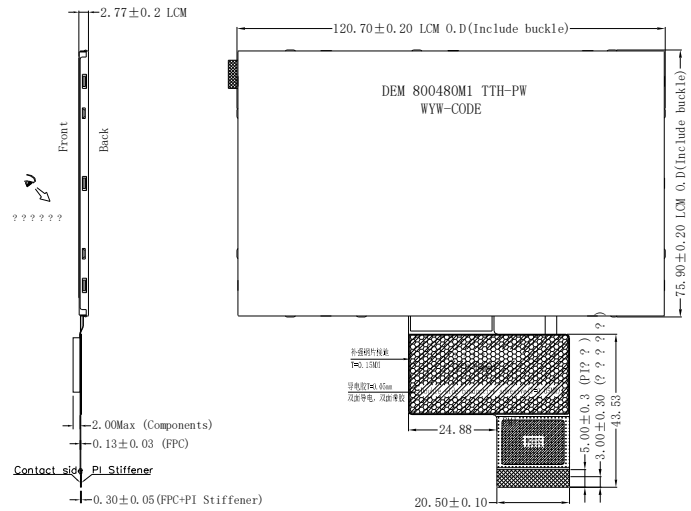
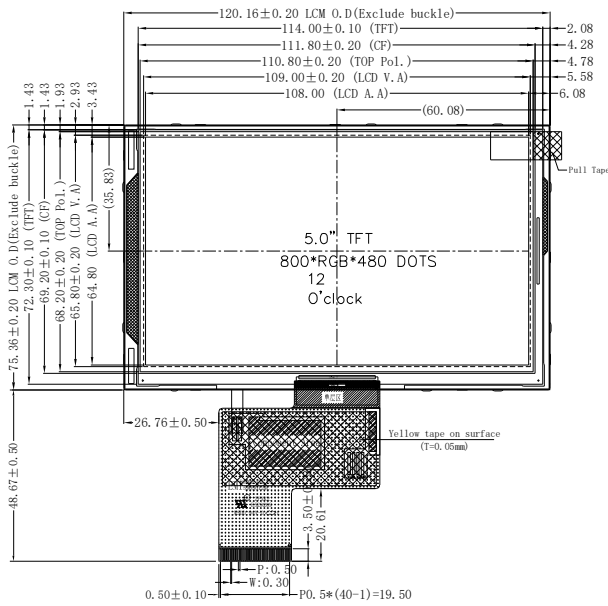

NOTE:

1. DISPLAY TYPE:5.0", TFT-LCD, 16.7M COLORS
2. DISPLAY MODE:NORMALLY WHITE, TN, TRANSFLECTIVE
3. VIEWING DIRECTION:12 O'CLOCK
4. LCM DRIVER IC:HX8264+HX8664 (COG)
LCM Interface:16/18/24BIT RGB
5. VDD/VCI:3.3V (TYP.)
6. OPERATING TEMP: -20° C TO 70° C
STORAGE TEMP: -30° C TO 80° C
7. BACK LIGHT:LED WHITE, 12 LED, 40mA, 16.8~19.6V
8. RoHS COMPLIANT.

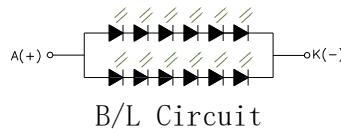

Pin	Name
1	VLED-
2	VLED+
3	GND
4	VDD
5	R0
6	R1
7	R2
8	R3
9	R4
10	R5
11	R6
12	R7
13	G0
14	G1
15	G2
16	G3
17	G4
18	G5
19	G6
20	G7
21	B0
22	B1
23	B2
24	B3
25	B4
26	B5
27	B6
28	B7
29	GND
30	PCLK
31	DISP
32	HSYNC
33	VSYNC
34	DE
35	NC
36	GND
37	XR (NC)
38	YD (NC)
39	XL (NC)
40	YU (NC)

3. Input Terminal Pin Assignment

NO	SYMBOL	DISCRIPTION	I/O
1	VLED-	Cathode pin OF backlight	P
2	VLED+	Anode pin of backlight	P
3	GND	Ground.	P
4	VDD	Supply voltage(3.3V).	P
5	R0	Red data input.	I
6	R1	Red data input.	I
7	R2	Red data input.	I
8	R3	Red data input.	I
9	R4	Red data input.	I
10	R5	Red data input.	I
11	R6	Red data input.	I
12	R7	Red data input.	I
13	G0	Green data input.	I
14	G1	Green data input.	I
15	G2	Green data input.	I
16	G3	Green data input.	I
17	G4	Green data input.	I
18	G5	Green data input.	I
19	G6	Green data input.	I
20	G7	Green data input.	I
21	B0	Blue data input.	I
22	B1	Blue data input.	I
23	B2	Blue data input.	I
24	B3	Blue data input.	I
25	B4	Blue data input.	I
26	B5	Blue data input.	I
27	B6	Blue data input.	I

28	B7	Blue data input.	I
29	GND	Ground.	P
30	PCLK	Clock signal. Latching data at the rising edge	I
31	DISP	Standby setting for testing, it should be connected to VDD in normal operation mode. If connected to GND, the IC is in standby mode.	I
32	HSYNC	Horizontal Sync input. Negative polarity.	I
33	VSYNC	Vertical Sync input. Negative polarity.	I
34	DE	Data input Enable. Active High to enable the data input Bus under "DE Mode".	I
35	NC	--	--
36	GND	Ground.	P
37	XR(NC)	--	--
38	YD(NC)	--	--
39	XL(NC)	--	--
40	YU(NC)	--	--

4. LCD Optical Characteristics

4.1 Optical Specification (Reflective)

Item	Symbol	Condition	Min.	Typ.	Max.	Unit.	Note
White Reflectance (with Polarizer)	R _w (%)	Θ=0	--	4.97	--	%	--
Contrast Ratio	CR	Normal	--	8	--		(1)(2)
Response Time	Rising	Viewing Angle	--	5	7	msec	(1)(3)
	Falling		--				
Color Gamut	S(%)		--	125	--	%	--
Color Filter Chromacity	White	W _X	--	0.344	--	--	(1)(4)
		W _Y	--	0.382	--		CA-310
Viewing Angle	Hor.	Θ _L	CR>10	--	55	--	--
		Θ _R		--	55	--	
	Ver.	Θ _U		--	60	--	
		Θ _D		--	60	--	

4.2 Optical Specification (Transmittance)

Item	Symbol	Condition	Min.	Typ.	Max.	Unit.	Note
White Transmittance (with Polarizer)	Rw (%)	$\Theta=0$	--	2.0		%	
Contrast Ratio	CR	Normal Viewing Angle	--	30	--		(1)(2)
Response Time	Rising	T_{R+T_F}	--	6	8	msec	(1)(3)
	Falling		--				
Color Gamut	S(%)		--	42	--	%	
Color Filter Chromacity	White	W_X	-0.04	0.304	+0.04		(1)(4) CA-310
		W_Y		0.321			
	Red	R_X		0.547			
		R_Y		0.342			
	Green	G_X		0.343			
		G_Y		0.547			
	Blue	B_X		0.157			
		B_Y		0.079			
Viewing Angle	Hor.	Θ_L	CR>10	--	65	--	(1)(4)
		Θ_R		--	65	--	
	Ver.	Θ_U		--	65	--	
		Θ_D		--	65	--	
Option View Direction	3 O'clock						

*The data comes from the LCD specification.

Measuring Condition

Measuring surrounding: dark rooms

Ambient temperature: 25°C±2°C

15min. warm-up time.

Measuring Equipment

FPM520 of Westar Display technologies, INC., which utilized SR-3 for Chromaticity and BM-5A for other optical characteristics.

Note (1): Definition of Viewing Angle:

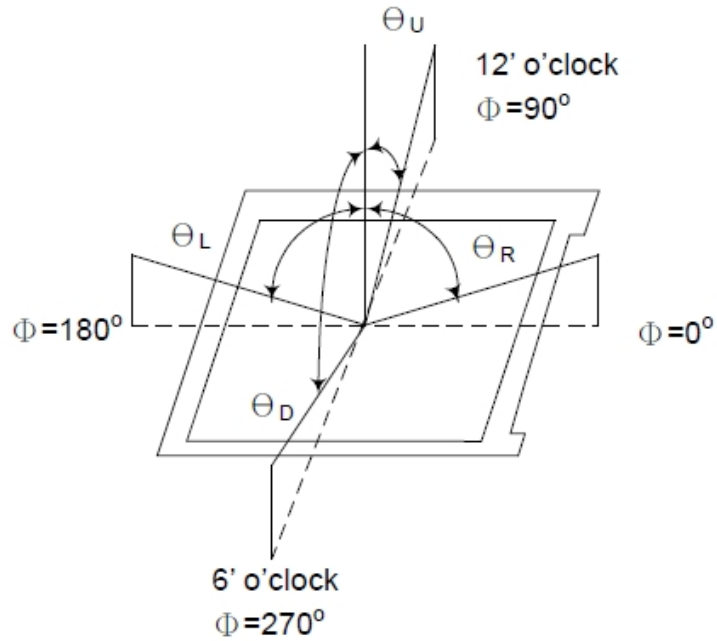

Note (2): Definition of Contrast Ratio(CR) :measured at the center point of panel

$$CR = \frac{\text{Luminance with all pixels white}}{\text{Luminance with all pixels black}}$$

Note (3): Response Time

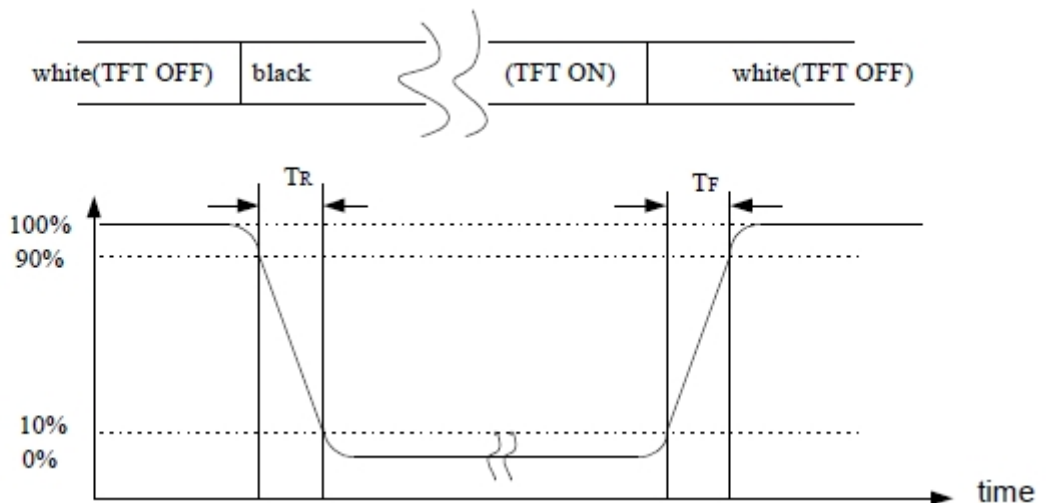

Note (4): Definition of optical measurement setup

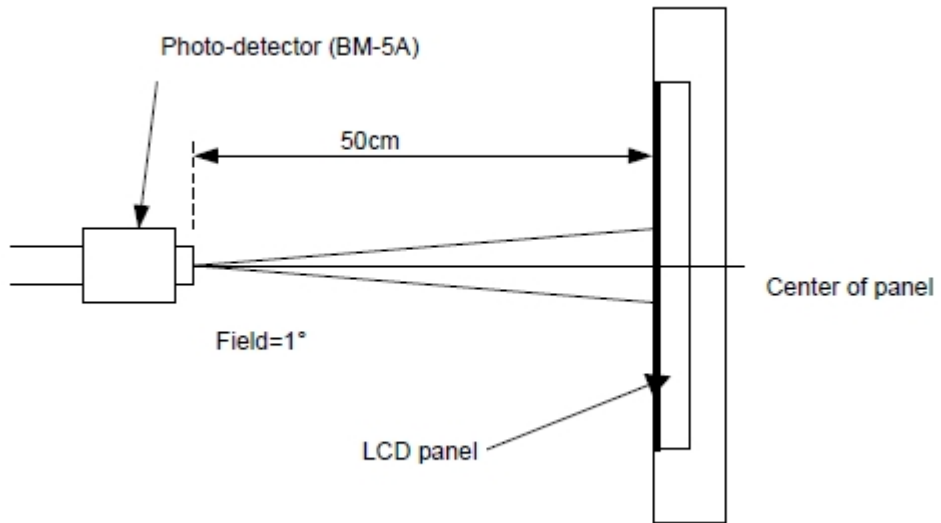

5. Electrical Characteristics

5.1 Absolute Maximum Rating

Characteristics	Symbol	Min.	Max.	Unit	Note
Digital Supply Voltage	VDD	-0.5	3.96	V	Note1
Operating Temperature	T _{OP}	-20	+70	°C	-
Storage Temperature	T _{ST}	-30	+80	°C	-

NOTE1: If the absolute maximum rating of even is one of the above parameters is exceeded even momentarily, the quality of the product may be degraded. Absolute maximum ratings, therefore, specify the values exceeding which the product may be physically damaged. Be sure to use the product within the range of the absolute maximum ratings.

5.2 DC Electrical Characteristics

Characteristics	Symbol	Min.	Typ.	Max.	Unit	Note
Digital Supply Voltage	VDD	2.7	3.3	3.6	V	--
Normal Mode Current	IDD	--	115	220	mA	--
Level Input Voltage	V _{IH}	0.7VDD	--	VDD	V	--
	V _{IL}	GND	--	0.3 VDD	V	--
Level Output Voltage	V _{OH}	VDD-0.4	--	--	V	--
	V _{OL}	GND	--	GND+0.4	V	--

5.3 LED Backlight Characteristics

The backlight system is edge-lighting type with 12 chips LED

Item	Symbol	Min.	Typ.	Max.	Unit	Note
Forward Current	I_F	--	40	--	mA	Note3
Forward Voltage	V_F	16.8	--	19.6	V	--
LCM Luminance	LV	150	200	--	cd/m ²	$I_F=40mA$
LED Lifetime	Hr	50000	--	--	Hours	Note1,2
Uniformity	Avg	80	--	--	%	Note4

Note1: LED life time (Hr) can be defined as the time in which it continues to operate under the condition: $T_a=25^{\circ}C\pm 3^{\circ}C$, typical IL value indicated in the above table until the brightness becomes less than 50%.

Note 2: The “LED life time” is defined as the module brightness decrease to 50% original brightness at $T_a=25^{\circ}C$ and $I_L=40\text{ mA}$. The LED lifetime could be decreased if operating I_L is larger than 40mA.

The constant current driving method is suggested.

Note 3: Based on the consideration of the display effect, if the backlight is used, it is recommended to use 15~20mA for the input current(Reduce current usage).

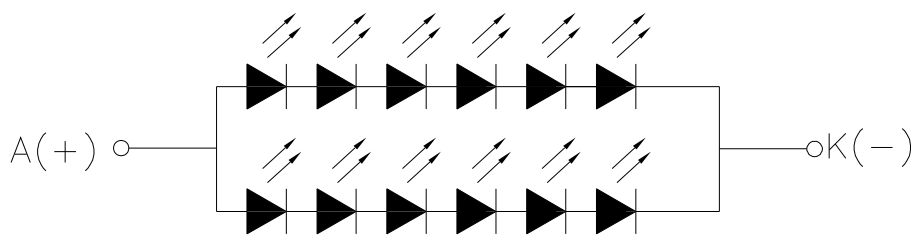

LED (B/L) CIRCUIT

Note (4) Luminance Uniformity of these 9 points is defined as below:

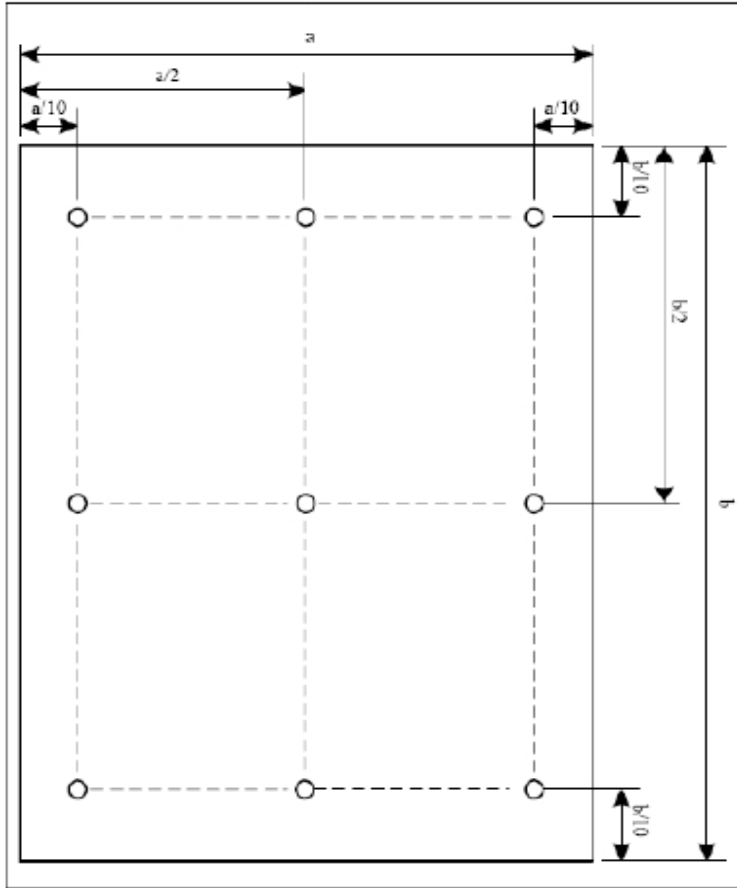

$$\text{Uniformity} = \frac{\text{minimum luminance in 9 points (1-9)}}{\text{maximum luminance in 9 points (1-9)}}$$

$$\text{Luminance} = \frac{\text{Total Luminance of 9 points}}{9}$$

6. AC Characteristics

6.1 AC Timing Characteristics

Parameter	Symbol	Spec.			Unit
		Min.	Typ.	Max.	
HS setup time	T_{hst}	8	-	-	ns
HS hold time	T_{hhd}	8	-	-	ns
VS setup time	T_{vst}	8	-	-	ns
VS hold time	T_{vhd}	8	-	-	ns
Data setup time	T_{dsu}	8	-	-	ns
Data hold time	T_{dhd}	8	-	-	ns
DE setup time	T_{esu}	8	-	-	ns
DE hold time	T_{ehd}	8	-	-	ns
VDD Power On Slew rate	T_{POR}	-	-	20	ms
RSTB pulse width	T_{Rst}	10	-	-	μ s
CLKIN cycle time	T_{cph}	20	-	-	ns
CLKIN pulse duty	T_{cwh}	40	50	60	%
Output stable time	T_{sst}	-	-	6	μ s

6.2 Timing Table

The display operation via the RGB interface is synchronized with the VSYNC, HSYNC, and DOTCLK signals. The data can be written only within the specified area with low power consumption by using window address function. The back porch and front porch are used to set the RGB interface timing.

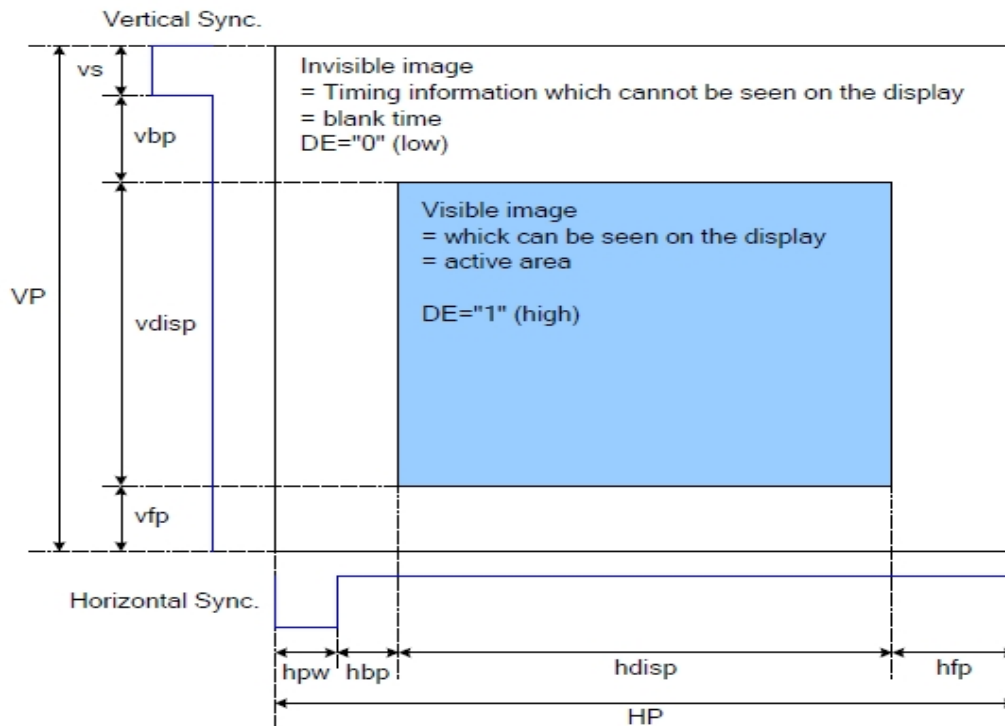

DRAM Access Area by RGB Interface

Please refer to the following table for the setting limitation of RGB interface signals.

Parameter	Symbol	Min.	Typ.	Max.	Unit
DCLK frequency	FCLK	--	30	--	MHz
Horizontal Address	hdisp	--	800	--	Clock
Horizontal Sync. Width	hpw	1	10	--	Clock
Horizontal Sync. Back Porch	hbp	1	88	--	Clock
Horizontal Sync. Front Porch	hfp	1	40	--	Clock
Vertical Address	vdisp	-	480	--	Line
Vertical Sync. Width	vs	1	8	--	Line
Vertical Sync. Back Porch	vbp	1	32	--	Line
Vertical Sync. Front Porch	vfp	1	13	--	Line
Frame-Rate	FR	--	60	--	Hz

7. LCD Module Out-Going Quality Level

7.1 VISUAL & FUNCTION INSPECTION STANDARD

7.1.1 Inspection Conditions

Inspection performed under the following conditions is recommended.

Temperature: 25°C±5°C

Humidity: 65%±10%RH

Viewing Angle: Normal Viewing Angle.

Illumination: Single fluorescent lamp (1000 to 1200Lux)

Viewing distance: 30-50cm

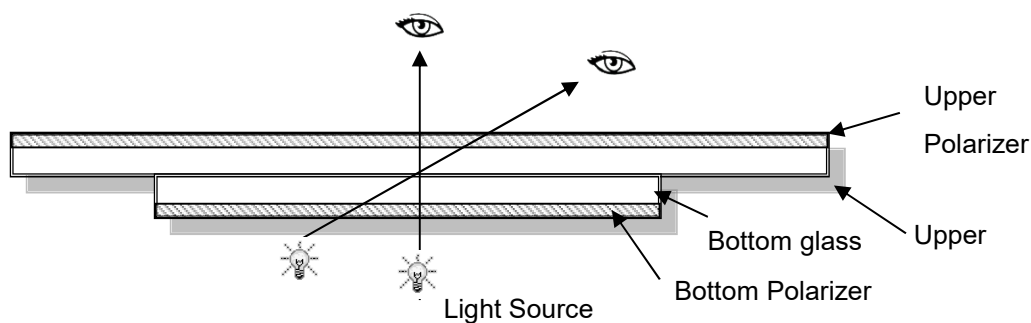

7.1.2 Definition

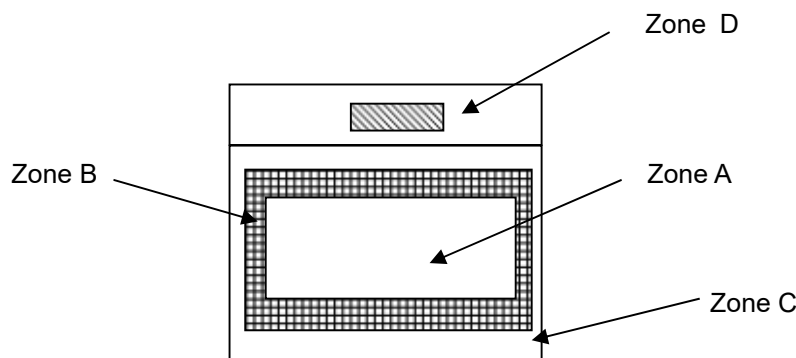

Zone A : Effective Viewing Area(Character or Digit can be seen)

Zone B : Viewing Area except Zone A

Zone C : Outside (Zone A+Zone B) which can not be seen after assembly by customer .)

Zone D : IC Bonding Area

Note: As a general rule ,visual defects in Zone C can be ignored when it doesn't effect product function or appearance after assembly by customer

7.1.3 Sampling Plan

According to GB/T 2828-2003, normal inspection, Class II

AQL:

Major Defect	Minor Defect
0.65	1.5

LCD: Liquid Crystal Display, LCM: Liquid Crystal Module

No	Items to be inspected	Criteria	Classification of defects
1	Functional defects	1) No display, Open or miss line 2) Display abnormally, Short 3) Backlight no lighting, abnormal lighting. etc...	Major
2	Missing	Missing components and etc...	
3	Outline dimension	Overall outline dimension beyond the drawing is not allowed, deformation and etc...	
4	Color tone	Color unevenness, refer to limited sample	Minor
5	Spot/Line defect	Light dot, Dim spot, (Note1) Polarizer Air Bubble, Polarizer accidented spot and etc...	
6	Soldering appearance	Good soldering , Peeling off is not allowed and etc...	
7	LCD/Polarizer	Black/White spot/line, scratch, crack, etc.	

Note1: a) Light dot: Dots appear bright and unchanged in size in which LCD panel is displaying' under black pattern.

b) Dim dot: Dots appear dark and unchanged in size in which LCD panel is displaying under pure red, green, blue picture.

7.1.4 Criteria (Visual)

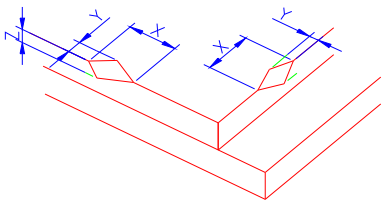
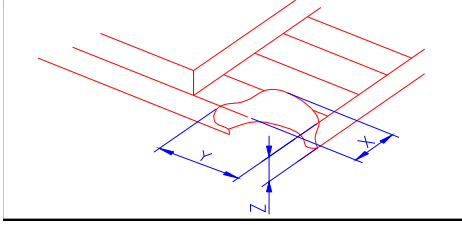
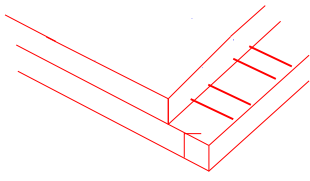
Number	Items	Criteria(mm)						
1.0 LCD Crack/Broken NOTE: X: Length Y: Width Z: Height L: Length of ITO, T: Height of LCD	(1) The edge of LCD broken	 <table border="1" data-bbox="751 611 1453 759"> <thead> <tr> <th>X</th> <th>Y</th> <th>Z</th> </tr> </thead> <tbody> <tr> <td>≤3.0mm</td> <td><Inner border line of the seal</td> <td>≤T</td> </tr> </tbody> </table>	X	Y	Z	≤3.0mm	<Inner border line of the seal	≤T
	X	Y	Z					
	≤3.0mm	<Inner border line of the seal	≤T					
(2) LCD corner broken	 <table border="1" data-bbox="831 1068 1374 1167"> <thead> <tr> <th>X</th> <th>Y</th> <th>Z</th> </tr> </thead> <tbody> <tr> <td>≤3.0mm</td> <td>≤L</td> <td>≤T</td> </tr> </tbody> </table>	X	Y	Z	≤3.0mm	≤L	≤T	
X	Y	Z						
≤3.0mm	≤L	≤T						
(3) LCD crack	 <p style="text-align: center;">Crack Not allowed</p>							

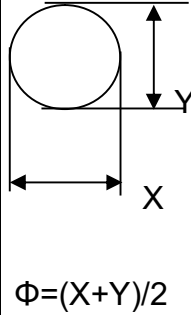
2.0	Spot defect	① light dot (black/white spot , pinhole, stain, etc.)																												
	 <p>$\Phi = (X+Y)/2$</p>	<table border="1" style="width: 100%; border-collapse: collapse;"> <thead> <tr> <th rowspan="2" style="text-align: center;">Zone Size (mm)</th> <th colspan="3" style="text-align: center;">Acceptable Qty</th> </tr> <tr> <th style="text-align: center;">A</th> <th style="text-align: center;">B</th> <th style="text-align: center;">C</th> </tr> </thead> <tbody> <tr> <td style="text-align: center;">$\Phi \leq 0.15$</td> <td colspan="3" style="text-align: center;">Ignore</td> </tr> <tr> <td style="text-align: center;">$0.15 < \Phi \leq 0.25$</td> <td colspan="3" rowspan="2" style="text-align: center;">Ignore</td> </tr> <tr> <td style="text-align: center;">$0.25 < \Phi \leq 0.4$</td> <td colspan="2" style="text-align: center;">3(distance \geq 10mm)</td> </tr> <tr> <td style="text-align: center;">$\Phi > 0.4$</td> <td colspan="3" style="text-align: center;">2(distance \geq 10mm)</td> </tr> <tr> <td style="text-align: center;">$\Phi > 0.4$</td> <td colspan="3" style="text-align: center;">0</td> </tr> </tbody> </table>			Zone Size (mm)	Acceptable Qty			A	B	C	$\Phi \leq 0.15$	Ignore			$0.15 < \Phi \leq 0.25$	Ignore			$0.25 < \Phi \leq 0.4$	3(distance \geq 10mm)		$\Phi > 0.4$	2(distance \geq 10mm)			$\Phi > 0.4$	0		
	Zone Size (mm)	Acceptable Qty																												
		A	B	C																										
$\Phi \leq 0.15$	Ignore																													
$0.15 < \Phi \leq 0.25$	Ignore																													
$0.25 < \Phi \leq 0.4$				3(distance \geq 10mm)																										
$\Phi > 0.4$	2(distance \geq 10mm)																													
$\Phi > 0.4$	0																													
② Dim spot (light leakage, dent, dark spot, etc)																														
<table border="1" style="width: 100%; border-collapse: collapse;"> <thead> <tr> <th rowspan="2" style="text-align: center;">Zone Size (mm)</th> <th colspan="3" style="text-align: center;">Acceptable Qty</th> </tr> <tr> <th style="text-align: center;">A</th> <th style="text-align: center;">B</th> <th style="text-align: center;">C</th> </tr> </thead> <tbody> <tr> <td style="text-align: center;">$\Phi \leq 0.15$</td> <td colspan="3" style="text-align: center;">Ignore</td> </tr> <tr> <td style="text-align: center;">$0.15 < \Phi \leq 0.25$</td> <td colspan="3" rowspan="2" style="text-align: center;">Ignore</td> </tr> <tr> <td style="text-align: center;">$0.25 < \Phi \leq 0.4$</td> <td colspan="2" style="text-align: center;">3(distance \geq 10mm)</td> </tr> <tr> <td style="text-align: center;">$\Phi > 0.4$</td> <td colspan="3" style="text-align: center;">2(distance \geq 10mm)</td> </tr> <tr> <td style="text-align: center;">$\Phi > 0.4$</td> <td colspan="3" style="text-align: center;">0</td> </tr> </tbody> </table>			Zone Size (mm)	Acceptable Qty			A	B	C	$\Phi \leq 0.15$	Ignore			$0.15 < \Phi \leq 0.25$	Ignore			$0.25 < \Phi \leq 0.4$	3(distance \geq 10mm)		$\Phi > 0.4$	2(distance \geq 10mm)			$\Phi > 0.4$	0				
Zone Size (mm)	Acceptable Qty																													
	A	B	C																											
$\Phi \leq 0.15$	Ignore																													
$0.15 < \Phi \leq 0.25$	Ignore																													
$0.25 < \Phi \leq 0.4$				3(distance \geq 10mm)																										
$\Phi > 0.4$	2(distance \geq 10mm)																													
$\Phi > 0.4$	0																													
③ Polarizer accidented spot																														
<table border="1" style="width: 100%; border-collapse: collapse;"> <thead> <tr> <th rowspan="2" style="text-align: center;">Zone Size (mm)</th> <th colspan="3" style="text-align: center;">Acceptable Qty</th> </tr> <tr> <th style="text-align: center;">A</th> <th style="text-align: center;">B</th> <th style="text-align: center;">C</th> </tr> </thead> <tbody> <tr> <td style="text-align: center;">$\Phi \leq 0.2$</td> <td colspan="3" style="text-align: center;">Ignore</td> </tr> <tr> <td style="text-align: center;">$0.2 < \Phi \leq 0.5$</td> <td colspan="3" rowspan="2" style="text-align: center;">Ignore</td> </tr> <tr> <td style="text-align: center;">$\Phi > 0.5$</td> <td colspan="2" style="text-align: center;">2(distance \geq 10mm)</td> </tr> <tr> <td style="text-align: center;">$\Phi > 0.5$</td> <td colspan="3" style="text-align: center;">0</td> </tr> </tbody> </table>			Zone Size (mm)	Acceptable Qty			A	B	C	$\Phi \leq 0.2$	Ignore			$0.2 < \Phi \leq 0.5$	Ignore			$\Phi > 0.5$	2(distance \geq 10mm)		$\Phi > 0.5$	0								
Zone Size (mm)	Acceptable Qty																													
	A	B	C																											
$\Phi \leq 0.2$	Ignore																													
$0.2 < \Phi \leq 0.5$	Ignore																													
$\Phi > 0.5$				2(distance \geq 10mm)																										
$\Phi > 0.5$	0																													
④ Polarizer Bubble																														
<table border="1" style="width: 100%; border-collapse: collapse;"> <thead> <tr> <th rowspan="2" style="text-align: center;">Zone Size (mm)</th> <th colspan="3" style="text-align: center;">Acceptable Qty</th> </tr> <tr> <th style="text-align: center;">A</th> <th style="text-align: center;">B</th> <th style="text-align: center;">C</th> </tr> </thead> <tbody> <tr> <td style="text-align: center;">$\Phi \leq 0.2$</td> <td colspan="3" style="text-align: center;">Ignore</td> </tr> <tr> <td style="text-align: center;">$0.2 < \Phi \leq 0.4$</td> <td colspan="3" rowspan="2" style="text-align: center;">Ignore</td> </tr> <tr> <td style="text-align: center;">$0.4 < \Phi \leq 0.5$</td> <td colspan="2" style="text-align: center;">2(distance \geq 10mm)</td> </tr> <tr> <td style="text-align: center;">$\Phi > 0.5$</td> <td colspan="3" style="text-align: center;">1</td> </tr> <tr> <td style="text-align: center;">$\Phi > 0.5$</td> <td colspan="3" style="text-align: center;">0</td> </tr> </tbody> </table>			Zone Size (mm)	Acceptable Qty			A	B	C	$\Phi \leq 0.2$	Ignore			$0.2 < \Phi \leq 0.4$	Ignore			$0.4 < \Phi \leq 0.5$	2(distance \geq 10mm)		$\Phi > 0.5$	1			$\Phi > 0.5$	0				
Zone Size (mm)	Acceptable Qty																													
	A	B	C																											
$\Phi \leq 0.2$	Ignore																													
$0.2 < \Phi \leq 0.4$	Ignore																													
$0.4 < \Phi \leq 0.5$				2(distance \geq 10mm)																										
$\Phi > 0.5$	1																													
$\Phi > 0.5$	0																													

3.0	LCD Pixel defect	<p>Pixel bad points</p> <table border="1"> <thead> <tr> <th data-bbox="478 248 687 304">Item</th> <th data-bbox="687 248 1201 304">Zone A</th> <th data-bbox="1201 248 1476 304">Acceptable Qty</th> </tr> </thead> <tbody> <tr> <td data-bbox="478 304 687 465" rowspan="3">Bright dot</td> <td data-bbox="687 304 1201 360">Random</td> <td data-bbox="1201 304 1476 360">N≤2</td> </tr> <tr> <td data-bbox="687 360 1201 416">2 dots adjacent</td> <td data-bbox="1201 360 1476 416">N≤0</td> </tr> <tr> <td data-bbox="687 416 1201 465">3 dots adjacent</td> <td data-bbox="1201 416 1476 465">N≤0</td> </tr> <tr> <td data-bbox="478 465 687 633" rowspan="3">Dark dot</td> <td data-bbox="687 465 1201 521">Random</td> <td data-bbox="1201 465 1476 521">N≤3</td> </tr> <tr> <td data-bbox="687 521 1201 577">2 dots adjacent</td> <td data-bbox="1201 521 1476 577">N≤0</td> </tr> <tr> <td data-bbox="687 577 1201 633">3 dots adjacent</td> <td data-bbox="1201 577 1476 633">N≤0</td> </tr> <tr> <td data-bbox="478 633 687 943">Distance</td> <td data-bbox="687 633 1201 943"> 1. Minimum Distance Between Bright dots. 2. Minimum Distance Between dark dots 3. Minimum Distance Between dark and bright dot. </td> <td data-bbox="1201 633 1476 943">5mm</td> </tr> <tr> <td colspan="2" data-bbox="478 943 1201 999">Total bright and dark dot</td> <td data-bbox="1201 943 1476 999">N≤4</td> </tr> </tbody> </table> <p data-bbox="478 999 1476 1055">Note:</p> <p data-bbox="478 1055 1476 1155">A) Bright dot: Dots appear bright and unchanged in size in which LCD panel is displaying under black pattern.</p> <p data-bbox="478 1155 1476 1256">B) Dark dot: Dots appear dark and unchanged in size in which LCD panel is displaying under pure red, green, blue picture.</p> <p data-bbox="478 1256 1476 1357">C) 2 dot adjacent = 1 pair = 2 dots</p> <p data-bbox="478 1357 1476 1413">Picture:</p> <div data-bbox="619 1447 699 1509"> </div> <div data-bbox="534 1550 751 1590">2 dot adjacent</div> <div data-bbox="1024 1447 1139 1509"> </div> <div data-bbox="973 1550 1193 1590">2 dot adjacent</div> <div data-bbox="628 1615 671 1727"> </div> <div data-bbox="486 1740 833 1783">2 dot adjacent (vertical)</div> <div data-bbox="1031 1615 1214 1727"> </div> <div data-bbox="962 1740 1279 1783">2 dot adjacent (slant)</div>	Item	Zone A	Acceptable Qty	Bright dot	Random	N≤2	2 dots adjacent	N≤0	3 dots adjacent	N≤0	Dark dot	Random	N≤3	2 dots adjacent	N≤0	3 dots adjacent	N≤0	Distance	1. Minimum Distance Between Bright dots. 2. Minimum Distance Between dark dots 3. Minimum Distance Between dark and bright dot.	5mm	Total bright and dark dot		N≤4
Item	Zone A	Acceptable Qty																							
Bright dot	Random	N≤2																							
	2 dots adjacent	N≤0																							
	3 dots adjacent	N≤0																							
Dark dot	Random	N≤3																							
	2 dots adjacent	N≤0																							
	3 dots adjacent	N≤0																							
Distance	1. Minimum Distance Between Bright dots. 2. Minimum Distance Between dark dots 3. Minimum Distance Between dark and bright dot.	5mm																							
Total bright and dark dot		N≤4																							

4.0	Line defect (LCD /Polarizer backlight black/white line, scratch, stain)  W: width, L : length N : Count	<table border="1"> <thead> <tr> <th rowspan="2">Width(mm)</th> <th rowspan="2">Length(m m)</th> <th colspan="3">Acceptable Qty</th> </tr> <tr> <th>A</th> <th>B</th> <th>C</th> </tr> </thead> <tbody> <tr> <td>$\Phi \leq 0.05$</td> <td>Ignore</td> <td colspan="2">Ignore</td> <td rowspan="3">Ignore</td> </tr> <tr> <td>$0.05 < W \leq 0.06$</td> <td>$L \leq 5.0$</td> <td colspan="2">$N \leq 3$</td> </tr> <tr> <td>$0.06 < W \leq 0.08$</td> <td>$L \leq 4.0$</td> <td colspan="2">$N \leq 2$</td> </tr> <tr> <td>$W > 0.08$</td> <td colspan="4">Define as spot defect</td> </tr> </tbody> </table>	Width(mm)	Length(m m)	Acceptable Qty			A	B	C	$\Phi \leq 0.05$	Ignore	Ignore		Ignore	$0.05 < W \leq 0.06$	$L \leq 5.0$	$N \leq 3$		$0.06 < W \leq 0.08$	$L \leq 4.0$	$N \leq 2$		$W > 0.08$	Define as spot defect			
		Width(mm)			Length(m m)	Acceptable Qty																						
			A	B		C																						
		$\Phi \leq 0.05$	Ignore	Ignore		Ignore																						
		$0.05 < W \leq 0.06$	$L \leq 5.0$	$N \leq 3$																								
$0.06 < W \leq 0.08$	$L \leq 4.0$	$N \leq 2$																										
$W > 0.08$	Define as spot defect																											
5.0	Electronic Components SMT.	Not allow missing parts, solderless connection, cold solder joint, mismatch, The positive and negative polarity opposite																										
6.0	Display color & Brightness.	1. Color: Measuring the color coordinates, The measurement standard according to the datasheet or samples. 2. Brightness: Measuring the brightness of White screen, The measurement standard according to the datasheet or Samples.																										
7.0	LCD Mura/Waving/ Hot spot	Not visible through 5% ND filter in 50% gray or judge by limit sample if necessary.																										

Criteria (functional items)

Number	Items	Criteria (mm)
1	No display	Not allowed
2	Missing segment	Not allowed
3	Short	Not allowed
4	Backlight no lighting	Not allowed

8. Reliability Test Result

Item	Condition	Inspection after test
High Temperature Operating	+70°C,96h	Inspection after 2~4hours storage at room temperature, the sample shall be free from defects: 1. Air bubble in the LCD; 2. Non-display; 3. Missing segments/line; 4. Glass crack; 5. Current IDD is twice higher than initial value.
Low Temperature Operating	-20°C, 96h	
High Temperature Storage	+80°C, 96h	
Low Temperature Storage	-30°C, 96h	
High Temperature & High	+60°C, 90% RH ,96h	
Thermal Shock (Non-operation)	-10°C, 30 min ↔ +60°C, 30 min, Change time: 5min 20CYC.	
ESD Test	C=150pF, R=330, 5points/panel Air:±8kV, 5times; Contact:±6kV, 5 times; (Environment: 15°C~35°C, 30%~60%).	
Vibration (Non-operation)	Frequency range: 10~55Hz, Stroke:1.5mm Sweep:10Hz~55Hz~10Hz 2 hours for each direction of X.Y.Z. (6 hours for total) (Package condition).	
Box Drop Test	1 Corner 3 Edges 6 faces,80cm(MEDIUM	

Remark:

1. The test samples should be applied to only one test item.
2. Sample size for each test item is 5~10pcs.
3. For Damp Proof Test, Pure water (Resistance > 10MΩ) should be used.
4. In case of malfunction defect caused by ESD damage, if it would be recovered to normal state after resetting, it would be judged as a good part.
5. Failure Judgment Criterion: Basic Specification, Electrical Characteristic, Mechanical Characteristic, Optical Characteristic.
6. The color fading mura of polarizing filter should not care.

9. Cautions and Handling Precautions

9.1 Handling and Operating the Module

- (1) When the module is assembled, it should be attached to the system firmly.
Do not warp or twist the module during assembly work.
- (2) Protect the module from physical shock or any force. In addition to damage, this may cause improper operation or damage to the module and back-light unit.
- (3) Note that polarizer is very fragile and could be easily damaged. Do not press or scratch the surface.
- (4) Do not allow drops of water or chemicals to remain on the display surface.
If you have the droplets for a long time, staining and discoloration may occur.
- (5) If the surface of the polarizer is dirty, clean it using some absorbent cotton or soft cloth.
- (6) The desirable cleaners are water, IPA (Isopropyl Alcohol) or Hexane.
Do not use ketene type materials (ex. Acetone), Ethyl alcohol, Toluene, Ethyl acid or Methyl chloride. It might permanent damage to the polarizer due to chemical reaction.
- (7) If the liquid crystal material leaks from the panel, it should be kept away from the eyes or mouth. In case of contact with hands, legs, or clothes, it must be washed away thoroughly with soap.
- (8) Protect the module from static; it may cause damage to the CMOS ICs.
- (9) Use finger-stalls with soft gloves in order to keep display clean during the incoming inspection and assembly process.
- (10) Do not disassemble the module.
- (11) Protection film for polarizer on the module shall be slowly peeled off just before use so that the electrostatic charge can be minimized.
- (12) Pins of I/F connector shall not be touched directly with bare hands.
- (13) Do not connect, disconnect the module in the "Power ON" condition.
- (14) Power supply should always be turned on/off by the item 6.1 Power On Sequence & 6.2 Power Off Sequence

9.2 Storage and Transportation.

- (1) Do not leave the panel in high temperature, and high humidity for a long time.
It is highly recommended to store the module with temperature from 0°C to 35°C and relative humidity of less than 70%
- (2) Do not store the TFT-LCD module in direct sunlight.
- (3) The module shall be stored in a dark place. When storing the modules for a long time, be sure to adopt effective measures for protecting the modules from strong ultraviolet radiation, sunlight, or fluorescent light.
- (4) It is recommended that the modules should be stored under a condition where no condensation is allowed. Formation of dewdrops may cause an abnormal operation or a failure of the module.
In particular, the greatest possible care should be taken to prevent any module from being operated where condensation has occurred inside.
- (5) This panel has its circuitry FPC on the bottom side and should be handled carefully in order not to be stressed.