

FEATURES

- 3.3V, 5V, 12V, and adjustable output versions
- Adjustable version output voltage range
- Guaranteed 5A output load current
- Input voltage range up to 40V
- 150KHz fixed frequency internal oscillator
- Excellent line and load regulation
- Thermal shutdown and current limit protection

APPLICATION

- Simple high-efficiency step-down regulator
- On-card switching regulators
- Positive to negative converter

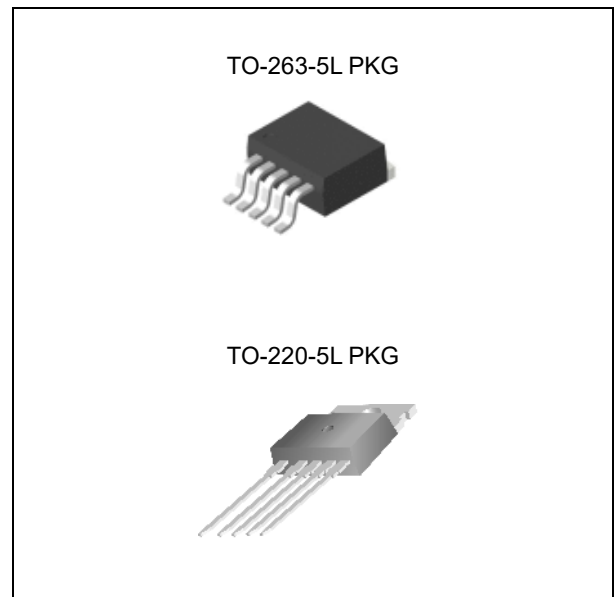

ORDERING INFORMATION

Device	Package
LM1501AGR-X.X	TO-263-5L
LM1501AGT-X.X	TO-220-5L

X.X = Output Voltage = 3.3, 5.0, 12, ADJ

DESCRIPTION

The LM1501AG series of regulators are monolithic integrated circuits that provide all the active functions for a step-down switching regulator, capable of driving a 5A load with excellent line and load regulation. These devices are available in fixed output voltages of 3.3V, 5V, 12V and an adjustable output version. Requiring a minimum number of external components, these regulators are simple to use and they include internal frequency compensation and a fixed-frequency oscillator. The LM1501AG series operates at a switching frequency of 150kHz thus allowing smaller sized filter components than what would be needed with lower frequency switching regulators.

Other features include a guaranteed $\pm 4\%$ tolerance on output voltage under specified input voltage and output load conditions, and $\pm 15\%$ on the oscillator frequency. External shutdown is included, featuring typically 80uA standby current. Self-protection features include a two stage frequency reducing current limit for output switch and an over temperature shutdown for complete protection under fault conditions.

ABSOLUTE MAXIMUM RATINGS (Note 1)

CHARACTERISTIC	SYMBOL	VALUE	UNIT
Maximum Input Supply Voltage	V_{IN_MAX}	45	V
ON/OFF Pin Input Voltage	$V_{ON/OFF}$	$-0.3 \leq V \leq +25$	V
Feedback Pin Voltage	V_{FB}	$-0.3 \leq V \leq +25$	V
Output Voltage to Ground (Steady State)	V_{OUT}	-1	V
Power Dissipation	P_D	Internally limited	W
Storage Temperature Range	T_{STG}	-65 to +150	°C
Operating Temperature Range	T_J	150	°C

5A, 150KHz, Step-Down Switching Regulator

LM1501AG

RECOMMENDED OPERATING CONDITIONS

CHARACTERISTIC	SYMBOL	MIN.	MAX.	UNIT
Supply Voltage	V_{IN}	-	40	V
Load Current	I _{LOAD}	-	5	A
Junction Temperature	T_J	-40	125	°C

ORDERING INFORMATION

V _{OUT}	PACKAGE	ORDER NO.	DESCRIPTION	STATUS
ADJ	TO-263-5L	LM1501AGR-ADJ	5A, 150KHz	Active
	TO-220-5L	LM1501AGT-ADJ	5A, 150KHz	Active
3.3V	TO-263-5L	LM1501AGR-3.3	5A, 150KHz	Active
	TO-220-5L	LM1501AGT-3.3	5A, 150KHz	Active
5.0V	TO-263-5L	LM1501AGR-5.0	5A, 150KHz	Active
	TO-220-5L	LM1501AGT-5.0	5A, 150KHz	Active
12V	TO-263-5L	LM1501AGR-12	5A, 150KHz	Active
	TO-220-5L	LM1501AGT-12	5A, 150KHz	Active

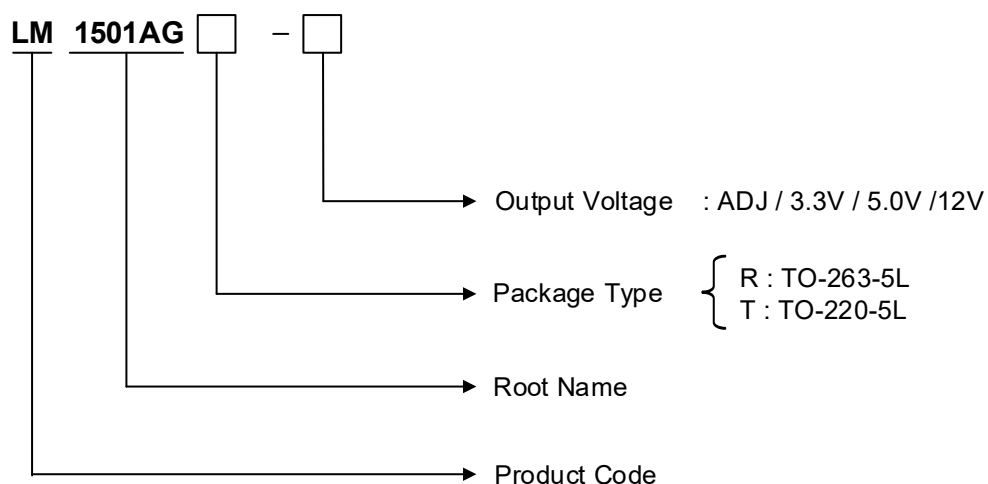

PIN CONFIGURATION

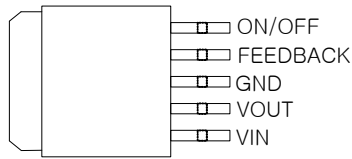

TO-263-5L

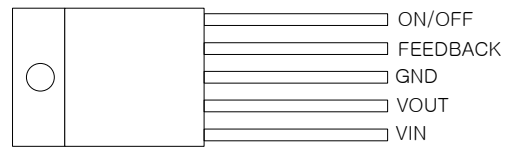

TO-220-5L

PIN DESCRIPTION

PIN NO.	TO-263-5L / TO-220-5L PKG	
	NAME	FUNCTION
1	VIN	Operating Input Voltage
2	OUTPUT	Switching Output Voltage
3	GND	Ground
4	FB	Output Voltage Feedback Control
5	ON/OFF	ON/OFF Shutdown

TYPICAL APPLICATION

- Fixed Output Voltage Version

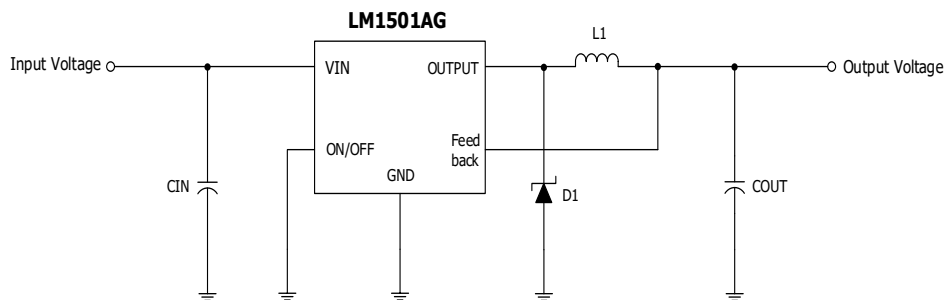

- Adjustable Output Voltage Version

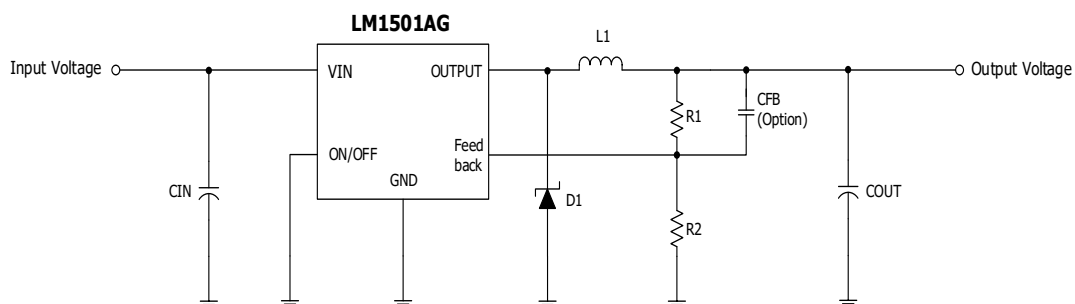

ELECTRICAL CHARACTERISTICS

Specification with standard type face are for $T_J=25^{\circ}\text{C}$, and those with **boldface type** apply over full Operating Temperature Range. Unless otherwise specified, $V_{IN}=12\text{V}$ for the 3.3V, 5V, and Adjustable version and $V_{IN}=24\text{V}$ for the 12V version. $I_{LOAD}=500\text{mA}$

CHARACTERISTIC	SYMBOL	TEST CONDITION	MIN. (Note 3)	TYP. (Note 2)	MAX. (Note 3)	UNIT	
SYSTEM PARAMETERS (Note 4)							
Efficiency	η	LM1501AG-ADJ	$V_{IN}=12\text{V}, I_{LOAD}=5\text{A}$		68	%	
		LM1501AG-3.3	$V_{IN}=12\text{V}, I_{LOAD}=5\text{A}$		68		
		LM1501AG-5.0	$V_{IN}=12\text{V}, I_{LOAD}=5\text{A}$		75		
		LM1501AG-12	$V_{IN}=18\text{V}, I_{LOAD}=5\text{A}$		84		
Output Voltage	V_{OUT}	LM1501AG-3.3	$5.5\text{V} \leq V_{IN} \leq 40\text{V}$	3.168	3.3	3.432	V
			$0.2\text{A} \leq I_{LOAD} \leq 5\text{A}$	3.135		3.465	
		LM1501AG-5.0	$8\text{V} \leq V_{IN} \leq 40\text{V}$	4.800	5.0	5.200	
			$0.2\text{A} \leq I_{LOAD} \leq 5\text{A}$	4.750		5.250	
		LM1501AG-12	$15\text{V} \leq V_{IN} \leq 40\text{V}$	11.520	12	12.480	
			$0.2\text{A} \leq I_{LOAD} \leq 5\text{A}$	11.400		12.600	
Feedback Voltage	V_{FB}	LM1501AG-ADJ	$5.2\text{V} \leq V_{IN} \leq 40\text{V}$	1.193	1.23	1.267	V
			$0.2\text{A} \leq I_{LOAD} \leq 5\text{A}$ V_{OUT} programmed for 3V	1.180		1.280	
DEVICE PARAMETERS							
Feedback Bias Current	I_{FB}	Adjustable Version Only, $V_{FB}=1.3\text{V}$		15	50	nA	
					100		
Oscillator Frequency	F_O	(Note 5)	127	150	173	kHz	
			120		180		
Saturation Voltage	V_{SAT}	$I_{OUT}=5\text{A}$ (Note 6, 7)		1.65	1.85	V	
					2.00		
Max Duty Cycle (ON)	DC	(Note 7)		100		%	
Max Duty Cycle (ON)		$I_{LOAD} \geq 4\text{A}$		50			
Min Duty Cycle (OFF)		(Note 8)		0			
Current Limit	I_{CL}	Peak Current (Note 6, 7)		6.9		A	
Thermal Shutdown Temperature	T_{SD}	(Note 10)		185		$^{\circ}\text{C}$	
Output Leakage Current	I_L	Output=0V (Note 6, 8)			50	μA	
		Output=-1V (Note 9)		10	30	mA	
Quiescent Current	I_Q	(Note 8)		5	10	mA	
Shutdown Current	$I_{SHUTDOWN}$	ON/OFF pin = 5V(OFF) (Note 9)		80	200	μA	
					250		

ON/OFF CONTROL						
ON/OFF Pin Logic Input Threshold voltage	V_{IH}	High (Regulator OFF)	2.0	1.3		V
	V_{IL}	Low (Regulator ON)			0.6	
ON/OFF Pin Logic Input current	I_H	$V_{LOGIC} = 2.5V$ (regulator OFF)		5	15	uA
	I_L	$V_{LOGIC} = 0.5V$ (regulator ON)		0.02	5	

Note 1: Absolute Maximum Rating indicate limits beyond which damage to the device may occur. Operating Ratings indicate condition for which the device is intended to be functional, but do not guarantee specific performance limits. For guaranteed specifications and test conditions, see the Electrical Characteristics.

Note 2: Typical numbers are at 25°C and represent the most likely norm.

Note 3: All limits guaranteed at room temperature (standard type face) and at temperature extremes (bold type face).

Note 4: External components such as the schottky diode, inductor, input and output capacitors, and voltage programming resistors can affect switching regulator system performance. When the LM1501AG is used as shown in the typical circuit, system performance will be as shown in system parameters section of Electrical Characteristics.

Note 5: The switching frequency is reduced when the second stage current limit is activated. The amount of reduction is determined by the severity of current over-load.

Note 6: No diode, inductor or capacitor connected to output pin.

Note 7: Feedback pin removed from output and connected to 0V to force the output transistor switch ON.

Note 8: Feedback pin removed from output and connected to 12V for the 3.3V, 5V, and the ADJ version, and 15V for the 12V version, to force the output transistor switch OFF.

Note 9: $V_{IN} = 40V$.

Note 10: Guaranteed by design, not tested.

TYPICAL OPERATING CHARACTERISTIC

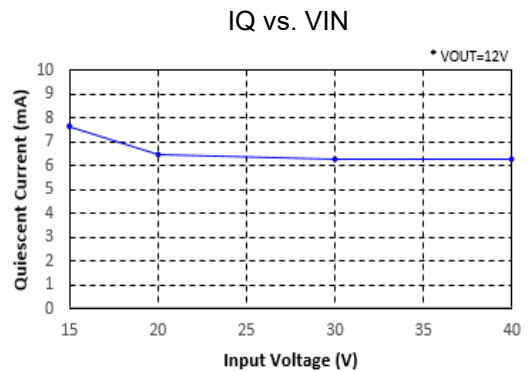
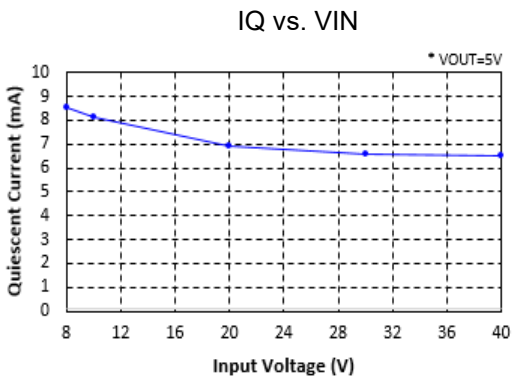
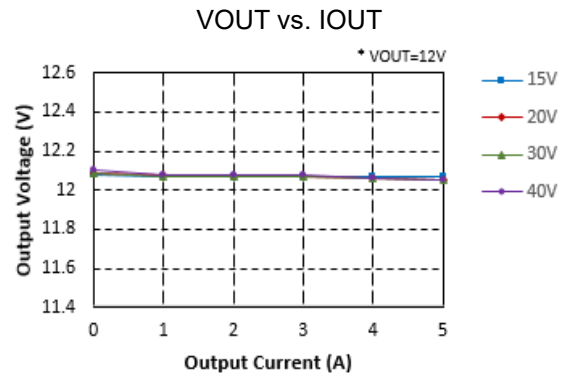
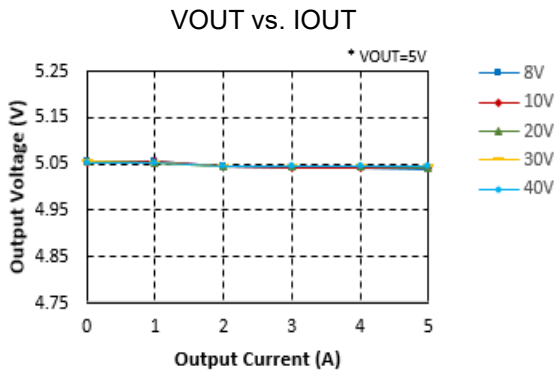
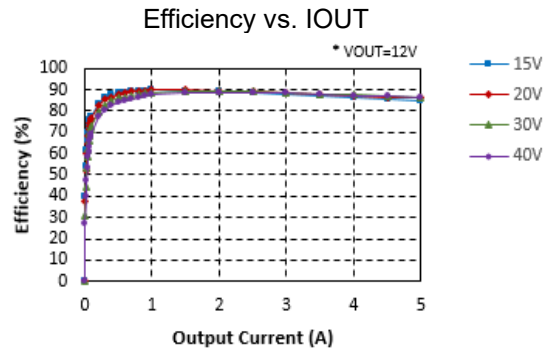
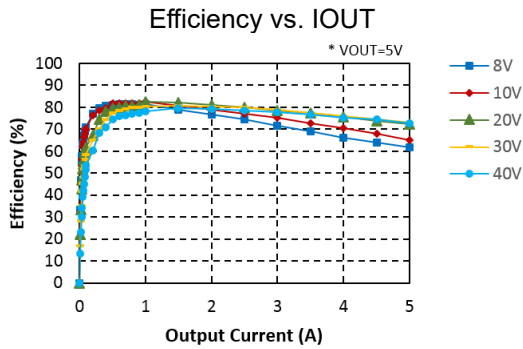

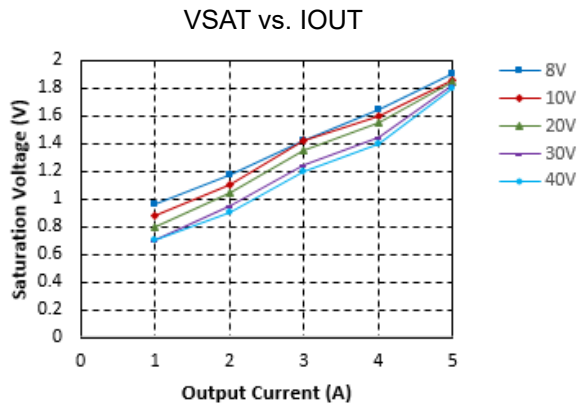

APPLICATION INFORMATION

As in any switching regulator, layout is very important. Rapidly switching currents associated with wiring inductance generate voltage transients which can cause problems. For minimal inductance and ground loops, the length of the wires should be kept as short as possible. Single-point grounding or ground plane construction should be used for best results. Keep the feedback wiring away from the inductor flux

- Fixed Output Voltage Version

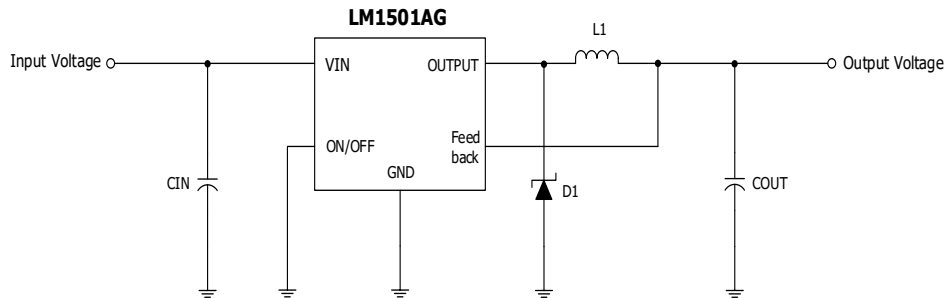

[Figure 1]

- Adjustable Output Voltage Version

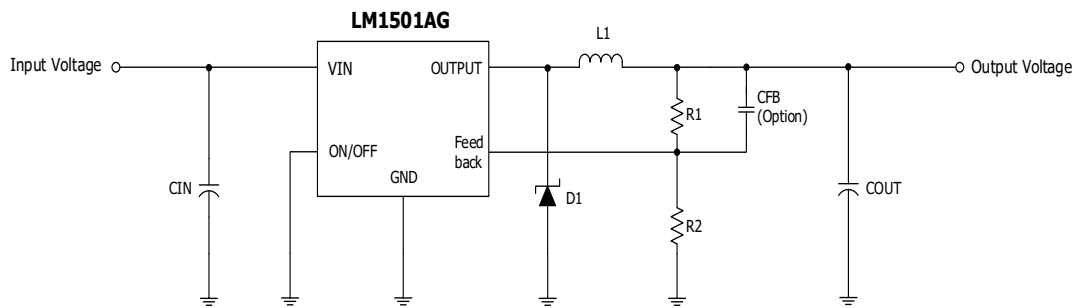

[Figure 2]

$$* V_{OUT} = V_{FB} \left(1 + \frac{R1}{R2} \right), \text{ Where } V_{FB} = 1.23V$$

REVISION NOTICE

The description in this datasheet is subject to change without any notice to describe its electrical characteristics properly.