



FEATURES

- ◆ LED DIMMER
- ◆ WHITE, SINGLE-COLOUR, TUNABLE-WHITE and DIM-to-WARM Light Control
- ◆ Power supply (DC IN): 12-24-48 Vdc (SELV)
- ◆ Output (L1, L2): constant voltage output (= DC IN) modulated for Resistive loads LED-strips and dimmable LED-modules
- ◆ PWM modulation, frequency settable via Dalcnet LightApp® mobile application from 307 to 4000 Hz
- ◆ Remote control via opto-isolated BUS (DALI)
- ◆ Device configuration via Dalcnet LightApp® mobile application and via DALI, settable parameters:
 - DALI address
 - Dimming Curve
 - Minimum, Maximum, Power-ON, and System Failure levels
 - Detection & Protection Features
 - Transition Parameters (Fade)
 - Groups and Scenarios
- ◆ ON/OFF and brightness soft dimming
- ◆ Suitable for use in Dry locations
- ◆ UL Features (see Table 5 for detailed technical specifications):
 - UL Recognized certified unit
 - Class 2 supply Input and Outputs (use Class 2 power supply only)
- ◆ Extended temperature range
- ◆ 100% Functional test

PRODUCT DESCRIPTION

SLIM-2CV-DALI is a 2-channel LED dimmer, PWM (Pulse Width Modulation) modulated at Constant Voltage (CV) and controllable via DALI (Digital Addressable Lighting Interface) digital protocol. SLIM-2CV-DALI can be supplied by a SELV constant voltage (12 ÷ 48) Vdc power supply and is suitable for driving loads such as White, single-colour, Tunable-White, and Dim-to-Warm LED-strips and dimmable LED-modules at constant voltage. The dimmer can deliver an output current of up to 10 A (total) and provides the following detections and protections: over voltage protection, under-voltage protection, reverse polarity protection, input fuse protection, open circuit detection, short circuit detection and protection.

Through the Dalcnet LightApp® mobile application and smartphone equipped with Near Field Communication (NFC) technology it is possible to configure multiple parameters when the device is turned off, including modulation frequency, adjustment curve and maximum/minimum brightness levels. Dalcnet LightApp® is free to download from the Apple APP Store and Google Play Store.

→ For the most up-to-date manual, please consult our website www.dalcnet.com or scan the QR Code on product label.



PRODUCT CODE

CODE	POWER SUPPLY	LED OUTPUTS	N° OF CHANNELS	REMOTE CONTROL	APP CONFIG
SLIM-2CV-DALI	12-24-48 Vdc	2 x 7A (tot. max 10A) ^{1,2}	2	DALI	LightApp®

Table 1: Product Code

PROTECTION AND DETECTION

The following table shows the types of incoming and outgoing protection/detection present on the device.

ACRONYM	DESCRIPTION	TERMINAL	PRESENT
IFP	Input Fuse Protection ³	DC IN	✓
OVP	Over Voltage Protection ³	DC IN	✓
UVP	Under Voltage Protection ³	DC IN	✓
RVP	Reverse Voltage Polarity ³	DC-IN	✓
OCD	Open-Circuit Detection	L1, L2	✓
SCD	Short-Circuit Detection	L1, L2	✓
SCP	Short-Circuit Protection	L1, L2	✓

Table 2: Detection and Protection features

REFERENCE STANDARDS

SLIM-2CV-DALI is compliant to the regulations listed in the table below.

STANDARD	TITLE
EN 55015	Limits and methods of measurement of radio disturbance characteristics of electrical lighting and similar equipment
EN 61547	Equipment for general lighting purposes – EMC immunity requirement
EN 61347-1	Lamp Controlgear – Part 1: General and safety requirement
EN 61347-2-13	Lamp controlgear - Part 2-13: Particular requirement for d.c. or a.c. supplied electronic Controlgear for LED modules
IEC 62386-101 ED2	Digital addressable lighting interface – Part 101: General requirements – System components
IEC 62386-102 ED2	Digital addressable lighting interface – Part 102: General requirements – Control gear
IEC 62386-209 ED2	Digital addressable lighting interface – Part 207: Particular requirements for control gear – Colour control (device type 8)
UL 1310	Standard for Safety. Class 2 Power Units.
UL 8750 & CSA C22.2 No. 250.13-17	Standard for Safety. Light Emitting Diode (LED) Equipment for Use in Lighting Products.

Table 3: Reference standards

¹ The maximum total output current depends on the operating conditions and ambient temperature of the system. For the correct configuration, check the maximum power that can be delivered in the §[Technical Specifications](#) and in the §[Thermal Characterization](#) sections.

² For specifications in a UL certified plant, refer to Table 5.

³ Protections refer to the control logic of the board.

TECHNICAL SPECIFICATIONS

CE TECHNICAL SPECIFICATIONS

Description	Name	Values			Unit of Measure	Note
		Min		Max		
INPUT (DC IN)						
Nominal supply voltage ⁴	V _{IN}	12	24	48	Vdc	-
Supply Voltage range	V _{IN-RNG}	10.8	÷	52.8	Vdc	-
Efficiency at full load	E _{EFF}	> 95			%	-
Standby power absorption	P _{STBY}	< 0.5			W	-
OUTPUT (L1, L2)						
Output Voltage	V _{OUT}	= V _{IN}			V	-
Output Current (max)	I _{OUT-CH}	-	-	7	A	-
	I _{OUT-TOT}	-	-	10	A	-
Rated Power Output	-	@12V	@24V	@48V	-	-
	P _{OUT-CH}	84	168	336	W	Per channel
	P _{OUT-TOT}	120	240	480	W	Total
Load type	L _{TYPE}	Resistive (LED)			-	Defined by design
DIMMING						
Dimming Curve	C _{DIM}	Logarithmic, Linear			-	Selection via Dalcnet LightApp [®]
Dimming Method	M _{DIM}	PWM			-	Pulse Width Modulation
PWM Frequency	f _{PWM}	307, 667, 1333, 2000, 4000			Hz	Selection via Dalcnet LightApp [®]
Dimming Resolution	Res _{DIM}	16			bit	Defined by design
Dimming range	RNG _{DIM}	0.1	÷	100	%	-
ENVIRONMENTAL						
Storage temperature	T _{STORE}	-40	÷	+60	°C	Minimum values defined by design
Working Ambient temperature	T _A	-10	÷	+60	°C	
Max Temperature @T _c point	T _C	-	-	+75	°C	-
Connectors Type	C _{TYPE}	Push-in terminals			-	-
Wiring Section	WS _{SOLID}	0.5	÷	1.5	mm ²	Defined by design
	WS _{STRAND}	20	÷	16	AWG	
Strip length	WS _{STRIP}	10			mm	-
Protection class	IP _{CODE}	IP20			-	-
Casing Material	MC	plastic			-	-
Packaging units (pieces/units)	PU	1			pcs	-
Mechanical Dimensions	-	L	H	D		
	MD	136	29	21	mm	Case
Packaging Dimensions	PD	147	34	29	mm	Packaging
Weight	W	56			g	Including packaging

Table 4: Technical specification

⁴ The product shall be supplied only by LED controlgear with SELV output at constant voltage V_{OUT} < 60 Vdc certified according to IEC/EN 61347.

UL TECHNICAL SPECIFICATIONS

SLIM-2CV-DALI for UL standard is classified as a built-in component and, as such, is subject to final system-level evaluation and certification in accordance with UL requirements. If installing in a UL certified plant, please refer to the values in Table 5: these values are binding to ensure UL compliance within the system, which the installer must strictly adhere to.

Description	Acronym	Values			Unit of Measure	Note	
		Min		Max			
UL Certification							
Product type	UL _{TYPE}				-	UL Recognized certified device	
Manufacturer certification file	UL _{FILE}	E514299			-	-	
INPUT (DC IN)							
UL Input type	TYPE _{IN}	CLASS 2			-	-	
Power Supply restrictions	SUP _{LIM}	CLASS 2 input only			-	Use Class 2 power supplies only	
Nominal supply voltage ⁴	V _{IN_UL}	12	24	48	Vdc	-	
Power Supply Range	V _{IN-RNG}	10.8	÷	48	Vdc	-	
Current absorption (max)	I _{IN_UL}	5	4.16	2.08	A	While respecting the limits on I _{OUT_UL} and P _{OUT_UL}	
Nominal Power absorption	P _{IN_UL}	60	100	100	W		
Efficiency at full load	E _{EFF}	> 95			%	-	
Standby power consumption	P _{STBY}	< 0.5			W	-	
OUTPUT (L1, L2)							
UL Output type	TYPE _{OUT}	CLASS 2			-	-	
Output voltage	V _{OUT}	= V _{IN}			-	-	
		@12V	@24V	@48V	-	-	
Output current (max)	I _{OUT_UL}	5	4.16	2.08	A	For each channel and total ⁵	
Nominal power output	P _{OUT_UL}	60	100	100	W		
Load type	L _{TYPE}	LED ARRAY			-	Resistive LED loads only	
DIMMING							
Curve	C _{DIM}	Logarithmic, Linear			-	Selection via Dalcnet LightApp®	
Method	M _{DIM}	PWM			-	Pulse Width Modulation	
PWM Frequency	f _{PWM}	307, 667, 1333, 2000, 4000			Hz	Selection via Dalcnet LightApp®	
Resolution	Res _{DIM}	16			bit	Defined by design	
Range	RNG _{DIM}	0.1	÷	100	%	-	
ENVIRONMENTAL							
Storage Temperature	T _{STORE}	-40	÷	+60	°C	Minimum values defined by design	
Working Environment Temp.	T _A	-10	÷	+40	°C	Minimum values defined by design	
Max Temperature at T _c points	T _C				+60	°C	Measured under Q2, U1 and T _c point
Working Environment type	ENV _{TYPE}	Dry location			-	-	
Connector type	C _{TYPE}	Push-in terminals			-	-	
Wiring Section	WS _{SOLID}	0.5	÷	1.5	mm ²	Defined by design	
	WS _{STRAND}	20	÷	16	AWG		
Stripping	WS _{STRIP}	10			mm	-	
Protection Class	IP _{CODE}	IP20			-	-	
Case Material	MC	Plastic			-	-	
Packaging Unit (Piece/Unit)	PU	1			pcs	-	
Dimensions	-	L	H	D	-	-	
	MD	136	29	21	mm	Plastic case	
	PD	147	34	29	mm	Packaging	
Weight	W	56			g	Including packaging	

Table 5: UL Technical specification

⁵ The product can drive up to two output channels. The interconnection of these outputs has not been evaluated. The acceptability of the interconnection of these outputs (and associated circuits) must be considered as part of the evaluation of the final installation.

T_c POINT POSITIONING

The following figures show the positions of the maximum temperature points (T_c point, highlighted in red) reached by the electronics inside the enclosure for CE and UL standards, located on the front (Top) and rear (Bottom) sides.



Figure 1: Position of the CE T_c point



Figure 2: Position of the UL T_c points

INSTALLATION



ATTENTION! Installation and maintenance must always be conducted in the absence of voltage.

Before continuing with the connection of the device to the power supply, make sure that the voltage of the power source is disconnected from the system.



The device should only be connected and installed by qualified personnel. All applicable regulations, legislation, standards, and building codes must be adhered to. Incorrect installation of the device may cause irreparable damage to the device and connected loads.

The following paragraphs show the diagrams of the dimmer's connection to the remote control, the load and the supply voltage. It is recommended to follow these steps to install the product safely:

1. **Load wiring:** connect the LED load positive to the "L1" terminal with the "+" symbol, and the LED load negatives to the "L1" terminal with the "-" symbol. Same connection for the second load on "L2" terminal.
2. **Remote Control wiring:** connect the DA data bus signals to the "DALI" terminals with the "DA" symbols.
3. **Power wiring:** connect a 12 Vdc, 24Vdc, or 48 Vdc constant voltage SELV power supply (depending on the nameplate data of the LED load) to the "+" and "-" terminals of the DC IN terminal.



LOAD WIRING

SLIM-2CV-DALI has 2 output channels that can be driven independently (e.g. for LED-strip and LED-modules) or depending on the white light temperature (e.g. for Tunable-White⁶ and Dim-to-Warm LED modules). Each type of load can be configured using properly the §DT8 - Temperature Correction, §DT6 - Dim-to-Warm, or §DT6 - 2 channels profile.

WHITE OR SINGLE-COLOUR LED LOADS DIAGRAM

The following connection diagram (Figure 3) allows to drive 2 white or single-colour LED load, on output channels L1 and L2.

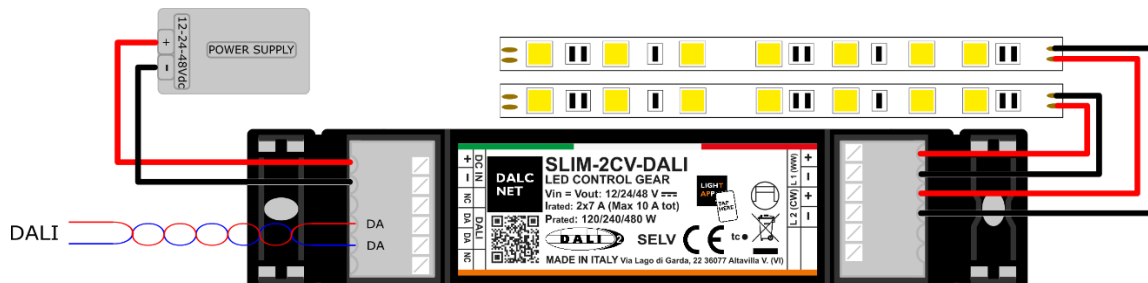

Figure 3: Wiring diagram for White or Single-Colour LED loads

⁶ "Tunable-White" refers to the ability of a lighting fixture to vary the colour temperature of white independently of its light intensity.

DIM-TO-WARM & TUNABLE-WHITE LED LOAD DIAGRAM

The following connection diagrams allows to drive LED loads for *Dim-to-Warm* and/or *Tunable-White* dimming, on output channels L1 (Warm-White) and L2 (Cool-White).

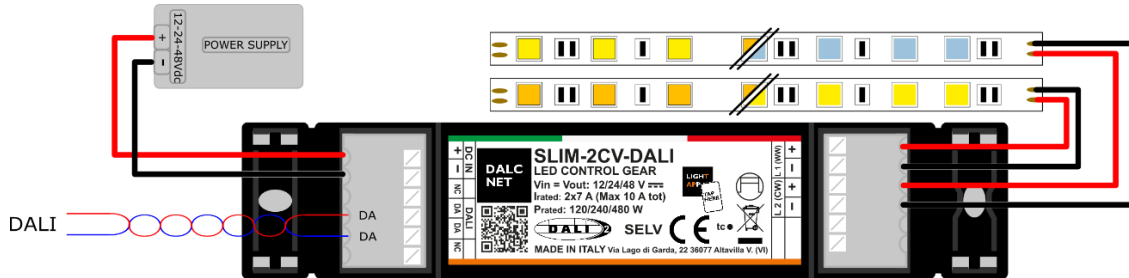

Figure 4: Wiring diagram for Dim-to-Warm & Tunable-White dimming on separate loads

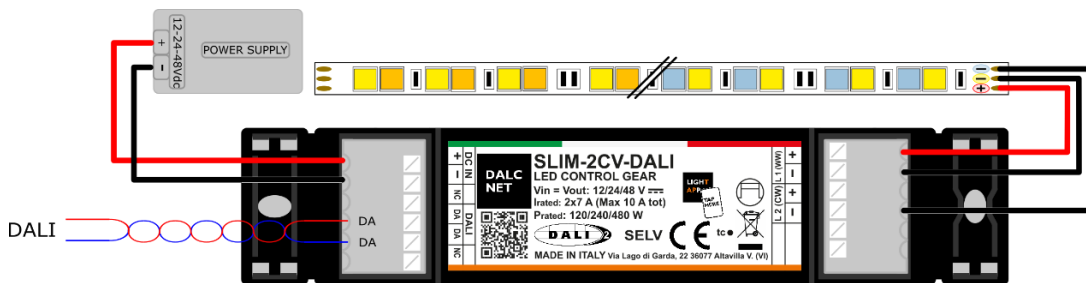



Figure 5: Wiring diagram for Dim-to-Warm and Tunable-White dimming on a single load

REMOTE CONTROL WIRING

SLIM-2CV-DALI can be controlled remotely via DALI digital bus by a simple two-wire cable (untwisted and unshielded). The control is conducted by a DALI Master, which provides commands to the devices in the DALI network and, if necessary, power supply⁷ to the network itself.

 To connect SLIM-2CV-DALI to the DALI network, simply connect the bus cables to the "DA" terminals of the "DALI" terminal: as different topologies are possible, it is not necessary to observe the polarity of the "DA+" and "DA-" signals of the bus when connecting.

DALI CABLING TOPOLOGIES

The DALI-2 protocol supports up to 64 Control Gear slave devices (e.g. SLIM-2CV-DALI) connected with different wiring topologies shown in Figure 6: Bus-wiring, Star-wiring, Tree-wiring, or Line-wiring. Other topologies are excluded.

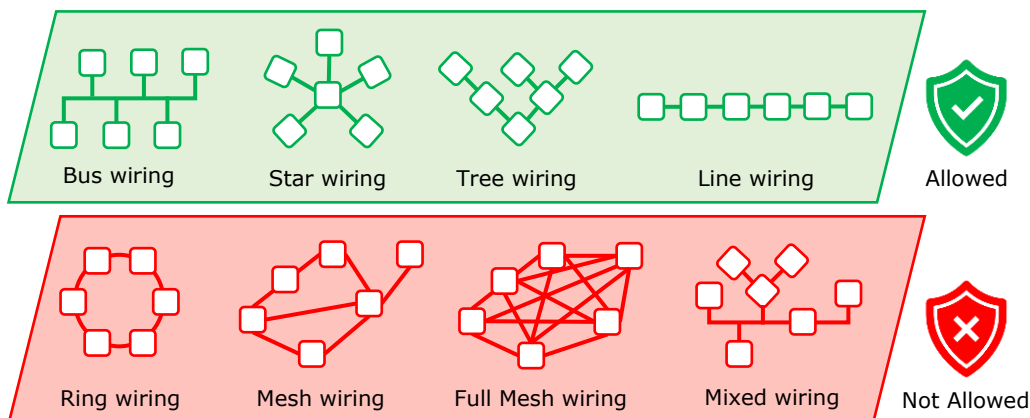

Figure 6: DALI wiring Topologies

⁷ The bus can be supplied by an external 16 Vdc power supply (or within the range of 12 ÷ 20 Vdc) or by a DALI Master with integrated bus power supply. For more information, please visit our website: www.dalcnet.com.

The Bus-wiring is shown as an example in the following figure.

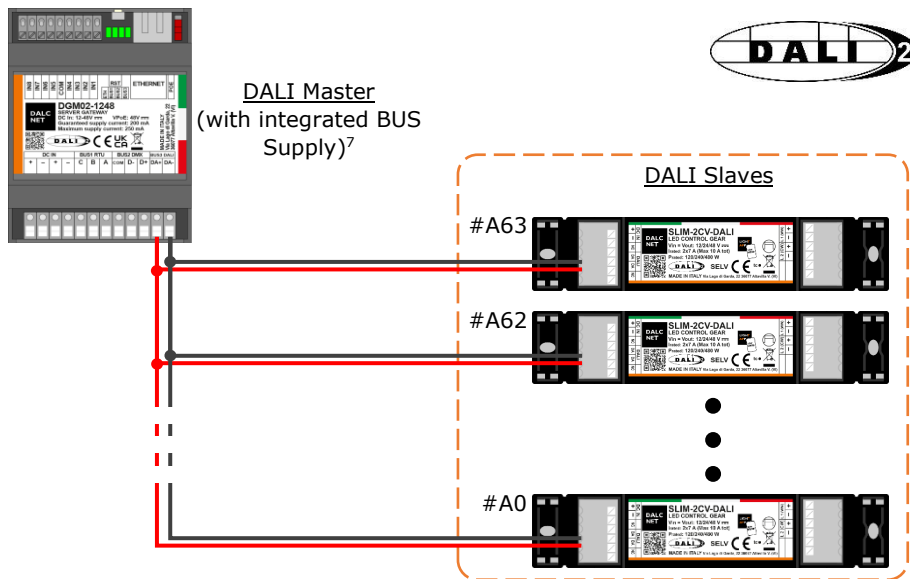

Figure 7: Remote Control Connection Topology, Bus-wiring

POWER SUPPLY WIRING



SLIM-2CV-DALI can be powered by a 12 Vdc, 24 Vdc or 48 Vdc constant voltage SELV (and Class 2 if installed within a UL certified plant) power supply and supplies the same voltage (dimmed) to the output. Once load and remote control (DALI bus) are wired, connect the power supply respecting the polarity conventions to the "+" and "-" labels of the DC IN terminal.

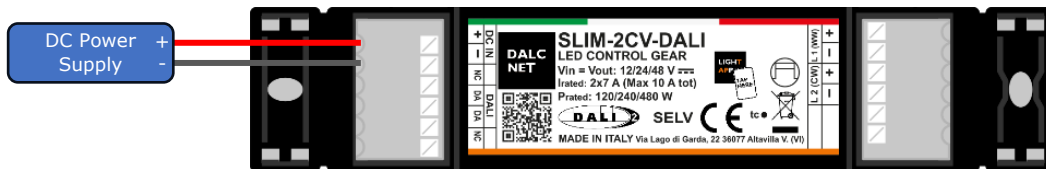

Figure 8: Power Supply wiring Diagram

REMOTE CONTROL: DALI

DALI (Digital Addressable Lighting Interface) is a protocol developed by the DALI Alliance (DIIA) to allow the management, configuration and programming of LED lighting systems in digital mode: through a two-way communication process between devices and control units, it is possible to execute ON, OFF or dimmer commands, report faults or information of various kinds. Based on a Master/Slave architecture, the DALI standard allows both single digital control of devices and programming in groups and/or broadcast.

In its second version, DALI-2 allows first full compatibility with the earlier protocol, and secondly brings numerous improvements compared to DALI-1:

1. Addition of lighting control devices: e.g. buttons, sensors, and LED drivers that were not included in the earlier version. In addition, to obtain DALI-2 certification, the new protocol requires the execution of functional and compliance tests by DIIA.
2. Introduction of the Multi Master architecture: with the regulation of the various lighting control devices, it is possible to send commands and signals to the DALI-2 bus from multiple sources, easing independent, immediate, and simultaneous data communication.
3. Development of functional and application standards: new extensions have been drawn up for DALI-2 devices, e.g. for emergency lighting or colour control, creating a new product standard for smart lighting and IoT systems called D4i.

PROFILE MAPPING: OPERATION MODE

The DALI protocol provides two configurations depending on the light characteristics to be obtained through the LED module connected to the outputs. Each profile is composed of a defined number of 8-bit channels, whose values can be set in the range (0 ÷ 254), each of which stands for a light characteristic (e.g. brightness, colour, temperature, etc.) to be modulated on the LED load. SLIM-2CV-DALI supports both DT8 and DT6 profiles to provide adjustment of the light intensity and temperature for the output channels.

DT8 - TEMPERATURE CORRECTION

With the "DT8" profile it is possible to adjust the temperature and the intensity of the light. The suitable load for this configuration is the Tunable-White LED modules, the connection diagram of which is given in the paragraph [§Dim-to-Warm & Tunable-White LED Load Diagram](#). This profile can be configured in the dedicated LightApp® section (see paragraph [§DALI parameters](#)).

Address	Function	Level
A0	INTENSITY	0...254
	COLOUR TEMP. CORRECTION	0...254

DT6 - DIM-TO-WARM

This profile allows you to adjust the colour temperature of the Dim-to-Warm LED module from a single DALI channel while maintaining almost unchanged light intensity. The suitable load for this configuration is the Dim-to-Warm LED modules, refer to the connection diagram in the paragraph [§Dim-to-Warm & Tunable-White LED Load Diagram](#). This profile can be configured in the dedicated LightApp® section (see paragraph [§DALI parameters](#)).

Address	Function	Level
A0	DIM to WARM	0...254

DT6 - 2 CHANNELS

This profile allows you to adjust the light intensity for each channel independently. In the [§White or Single-Colour LED Loads](#) section, it is possible to find details on the type of load and the most suitable connection diagram for this operating mode. It is understood that this profile can be used with all the other types of load proposed in this document (see [§Load wiring](#)) by configuring the device in the dedicated LightApp® section (see [§DALI parameters](#)).

Address	Function	Level
A0	DIMMER CH1	0...254
A1	DIMMER CH2	0...254

FLICKER PERFORMANCE

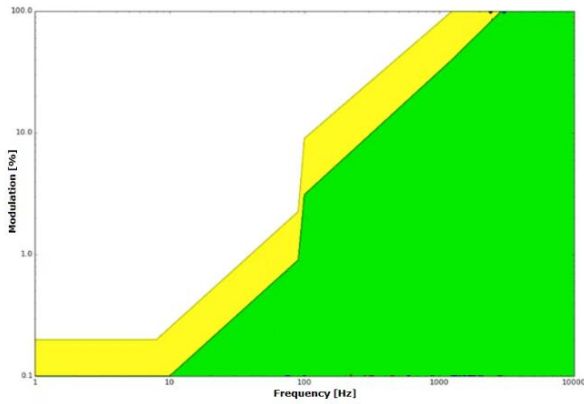

Figure 9: Flickering Perception Threshold

Thanks to the 4 kHz modulation, the SLIM-2CV-DALI effectively reduces the occurrence of the Flicker phenomenon. Depending on an individual's sensitivity and the nature of their activities, flickering can affect one's well-being, even if the changes in luminance are beyond the threshold detectable by the human eye.

The graph shows the phenomenon of Flickering in function at the frequency, measured throughout the dimming range.

The results show the low-risk zone (yellow) and the no-effect zone (green), defined by IEEE 1789-2015⁸.

THERMAL CHARACTERIZATION

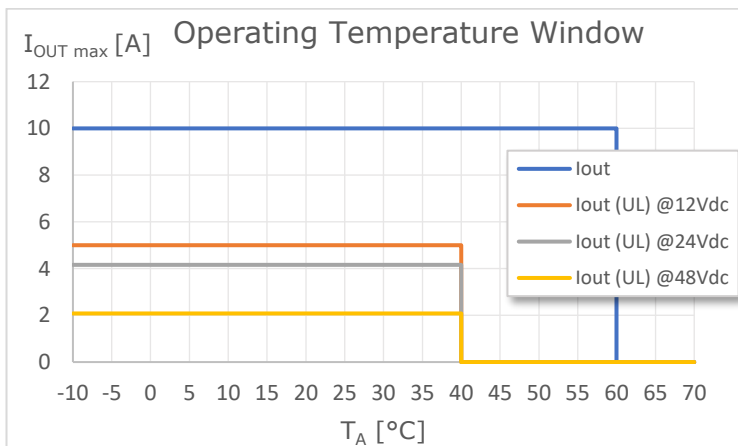

Figure 10: Operating Temperature Window

Figure 10 shows the maximum output current values that can be provided by the SLIM-2CV-DALI as a function of the operating temperature⁹ (or ambient temperature, T_A) of the operation, summarized below:

- ◆ $T_A = (-10 \div +60) \text{ }^\circ\text{C} \rightarrow I_{OUT} \leq 10 \text{ A}$
- ◆ $T_A = (-10 \div +40) \text{ }^\circ\text{C} \rightarrow I_{OUT_UL@12V} \leq 5 \text{ A}$
- ◆ $T_A = (-10 \div +40) \text{ }^\circ\text{C} \rightarrow I_{OUT_UL@24V} \leq 4.16 \text{ A}$
- ◆ $T_A = (-10 \div +40) \text{ }^\circ\text{C} \rightarrow I_{OUT_UL@48V} \leq 2.08 \text{ A}$

These maximum current values can only be applied under suitable ventilation conditions.

DIMMING CURVES

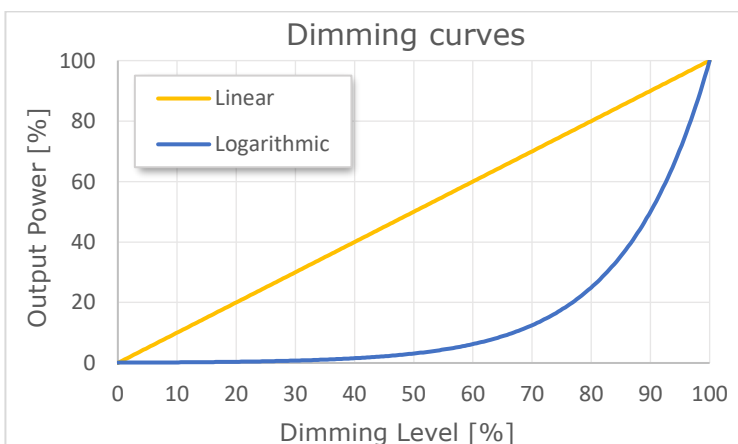

Figure 11: Normalized Dimming curve

Figure 11 shows the dimming curves supported by the SLIM-2CV-DALI dimmer. Curve selection can be done using the Dalcnet LightApp[®] (see §DALI parameters section of this manual).

⁸ Institute of Electrical and Electronics Engineers (IEEE). *IEEE std 1789: Recommended Practices for Modulating Current in High-Brightness LEDs for Mitigating Health Risks to Viewers.*

⁹ If the product is installed inside an electrical panel and/or junction box, T_A refers to the temperature inside the panel/box.

MECHANICAL DIMENSIONS

Figure 12 details the mechanical measurements and the overall dimensions [mm] of the outer casing.

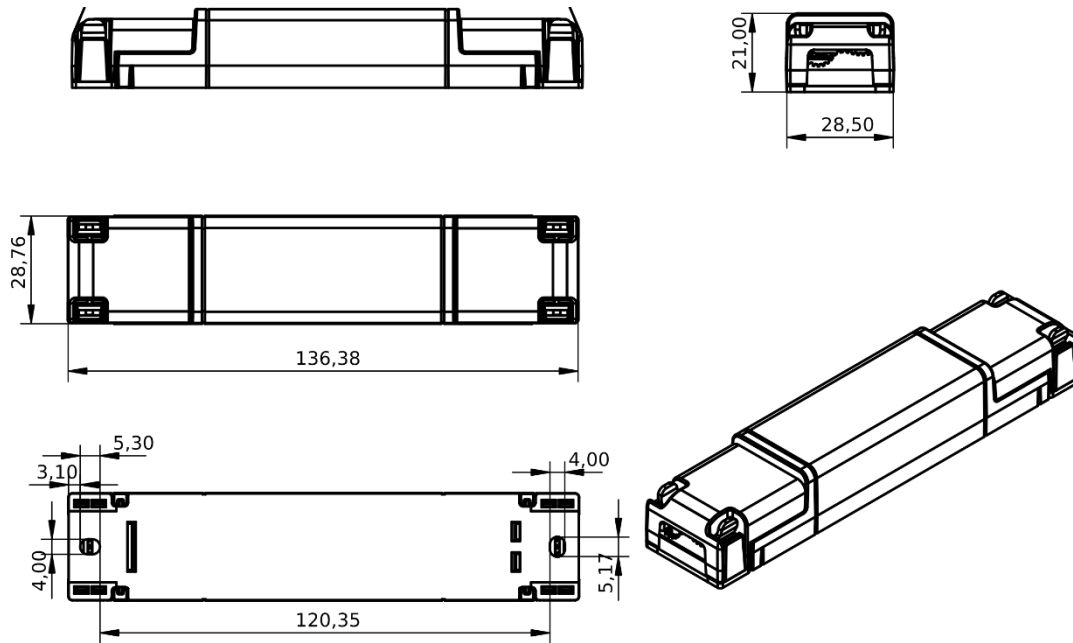

Figure 12: Mechanical dimensions

TECHNICAL NOTES

INSTALLATION



WARNING! Installation and maintenance should always be performed in the absence of DC voltage. Before proceeding with the installation, adjustment, and connection of the device to the power supply, make sure that the voltage is disconnected from the system.

WARNING! Risk of fire or electric shock. Do not interconnect the output terminations. *Risque d'incendie ou de décharge électrique. Ne pas interconnecter les terminaisons de sortie.*



The device should only be connected and installed by qualified personnel. All applicable regulations, legislation, standards, and building codes in force in the respective countries must be adhered to. Incorrect installation of the device may cause irreparable damage to the device and connected loads.

Maintenance must only be carried out by qualified personnel in compliance with current regulations.

The product must be installed inside an electrical panel and/or junction box that is protected against surges/overvoltage.

The product is suitable for use in dry places, away from sources of moisture. Installation and use must take place in a dry environment.

The external power supply must be protected. The product must be protected by a properly sized circuit breaker with overcurrent protection.

Keep 230 Vac (LV) circuits and non-SELV circuits separate from SELV safety ultra-low voltage circuits and any product connections. It is strictly forbidden to connect, for any reason, directly or indirectly, the 230 Vac mains voltage to the product (BUS terminals included).

The product must be installed in a vertical or horizontal position, i.e. with the faceplate/label/top cover facing up or vertically. No other positions are allowed. The bottom position, i.e. with the faceplate/label/top cover facing downwards, is not allowed.

During installation, it is recommended to reserve adequate space around the device to facilitate its accessibility in case of future maintenance or updates (e.g. via smartphone, NFC).



Use in thermally harsh environments may limit the output power of the product.

For devices embedded within luminaires, the T_A ambient temperature range is a guideline to be carefully observed for the optimal operating environment. However, the integration of the device within the luminaire must always ensure proper thermal management (e.g. correct mounting of the device, proper ventilation, etc.) so that the temperature at the T_C point does not exceed its maximum limit under any circumstances. Proper operation and durability are only guaranteed if the maximum temperature of the T_C point is not exceeded under the conditions of use.

POWER AND LOAD



The device must be powered only with SELV type power supplies (and Class 2 if installed within a UL certified plant) with limited current at constant voltage, short circuit protection and power suitably sized according to the specifications indicated in the product data sheet. No other types of power are allowed.

Size the power of the power supply respect to the load connected to the device. If the power supply is oversized compared to the maximum current drawn, insert an overcurrent protection between the power supply and the device.

Connecting to an unsuitable power supply may cause the device to work outside of the specified design limits, voiding its warranty.

In the case of power supplies equipped with earth terminals, it is mandatory to connect ALL the protection earth points (PE= Protection Earth) to a state-of-the-art and certified earthing system.

The power cables of the device must be correctly sized with reference to the connected load and must be isolated from any wiring or equal to non-SELV voltage. It is recommended not to exceed 10m of connection between the power source and the product. Use double-insulated cables. If you want to use connection cables between the power source and the product longer than 10m, the installer must ensure the correct operation of the system. In any case, the connection between the power supply and the product must not exceed 30m.

The manufacturer recommends ensuring a cumulative leakage current of less than 3.5 mA on the control circuit.



The device has been designed to work with Resistive LED loads only. Connecting and powering unsuitable loads may cause the device to work outside of the specified design limits, voiding its warranty. In general, the operating conditions of the device should never exceed the specifications wrote down in the product data sheet.

Observe the intended polarity between the LED module and the device. Any polarity reversal results in no light emission and can often damage the LED modules.

It is recommended that the connection cables between the product and the LED module be less than 3m long. Cables must be properly sized and should be insulated from any non-SELV wiring or parts. It is recommended to use double-insulated cables. If you want to use connection cables between the product and the LED module longer than 3m, the installer must ensure the correct operation of the system. In any case, the connection between the product and the LED module must not exceed 30m.

It is not allowed to connect different types of loads in the same output channel.

The interconnection of the output channels has not been evaluated. The acceptability of the interconnection of these outputs (and associated circuits) must be considered as part of the evaluation of the final installation. In case of installation in a UL certified plant, please refer to the evaluation of the final system.

REMOTE CONTROL



It is absolutely forbidden to connect, for any reason, directly or indirectly, the 230 Vac mains voltage to the DALI terminals of the BUS.

The length and type of cables connecting to the buses must follow the specifications of the respective protocols and current regulations. They must be isolated from any non-SELV wiring or live parts. It is recommended to use double-insulated cables.

All devices and control signals connected to the bus must be of the SELV type (the connected devices must be SELV or otherwise provide a SELV signal).

NFC (NEAR FIELD COMMUNICATION) WARNINGS



The NFC antenna is located inside the device, the contact surface of which is indicated with the symbol . Position your smartphone so that its NFC antenna is in contact with the symbol on the device.



The location of the NFC sensor on the smartphone is dependent on the make and model of the smartphone itself. Therefore, it is recommended to refer to your smartphone's manual or the manufacturer's website to accurately determine where the NFC sensor is located. In most cases, the NFC reader is located on the back side near the top of the smartphone.

NFC technology works optimally with non-metallic materials. Therefore, it is not recommended to place the device near metal objects or reflective surfaces when using NFC.

For reliable communication, make sure that the contact surface is not covered or that it is free of metal objects, wiring, or other electronic devices. Any impediments could affect the quality of communication.

NFC technology works at a short distance, generally within a few centimeters. Make sure your device and smartphone are close enough to allow communication.

During firmware update and configuration, you should keep stable contact (possibly without movement) between your smartphone and the device for the entire duration of the process (typically between 3 and 60 seconds). This ensures that the update goes smoothly, and that the device is ready to use after the process is complete.

LEGAL NOTES

TERMS OF USE







Dalcnet Srl (hereinafter referred to as "the Company") reserves the right to make changes to this device, in whole or in part, without prior notice to the customer. Such changes may affect technical aspects, functionality, design, or any other element of the device. The company is not required to notify you of such changes and that your continued use of the device will constitute your acceptance of the changes.

The company is committed to ensuring that any changes do not compromise the essential functionality of the device and that they comply with applicable laws and regulations. In the event of substantial changes, the company undertakes to provide clear and timely information on the same.

The customer is advised to periodically consult the www.dalcnet.com website or other official sources to check for any updates or changes to the device.

SYMBOLS

	All products are manufactured in compliance with European Regulations, as reported in the Declaration of Conformity.
	Independent lamp Controlgear: lamp controlgear consisting of one or more separate elements so designed that it can be mounted separately outside a luminaire, with protection according to the marking of the lamp controlgear and without any additional enclosure.
CLASS 2	UL Class 2 device: product compliant to UL1310 standard, designed to ensure that that the device's outputs are safe to touch and does not necessitate additional safety protections at the level of outputs. Essentially, the device is designed to minimize the risk of electric shock or overheating, thereby ensuring its safety for use in various contexts.
	UL Recognized certified unit for Canadian and U.S. markets: see technical specifications in Table 5.
SELV	"Very Low Safety Voltage" in a circuit isolated from the mains supply by insulation not less than that between the primary and secondary circuits of a safety isolation transformer according to IEC 61558-2-6.
	At the end of its useful life, the product described in this data sheet is classified as waste from electronic equipment and cannot be disposed of as unsorted municipal solid waste. Warning! Improper disposal of the product may cause serious harm to the environment and human health. For proper disposal, inquire about the collection and treatment methods provided by the local authorities.

LIGHTAPP

LIGHT APP

LightApp® is the official Dalcnet application through which it is possible to configure, in addition to the functions of the SLIM-2CV-DALI, also all the different Dalcnet products equipped with NFC technology.

Dalcnet LightApp® can be downloaded free of charge from the Apple App Store and Google Play Store.



START-UP AND FIRST INSTALLATION

START SCREEN - CONFIGURE

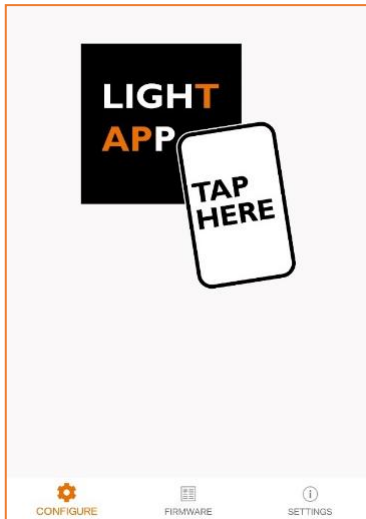

On this screen, the app waits for the device parameters to be read.

To read the parameters, simply bring the back of the smartphone close to the device's label. The read-sensitive zone of the smartphone may vary depending on the model.

Once the connection is set up, a quick loading screen will appear. You must remain in position with your smartphone until the parameters are fully loaded.

iOS variant: To read the parameters, you need to press the SCAN button at the top right. A pop-up will appear showing when your smartphone is ready to scan. Move the smartphone closer to the device and remain in place until the parameters are fully loaded.

SETTINGS

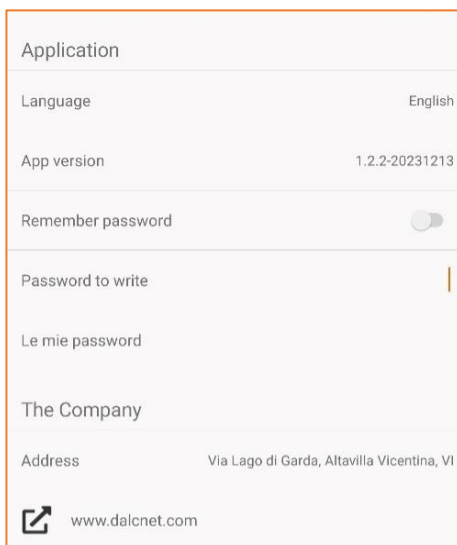

On the Settings page, you can:

- ◆ Setting the language of the app (Italian or English)
- ◆ View the app version
- ◆ Enable password saving on your smartphone
- ◆ Setting the Password for Writing Parameters
- ◆ View your saved passwords
- ◆ View the references of the distribution company (Dalcnet Srl)

FIRMWARE

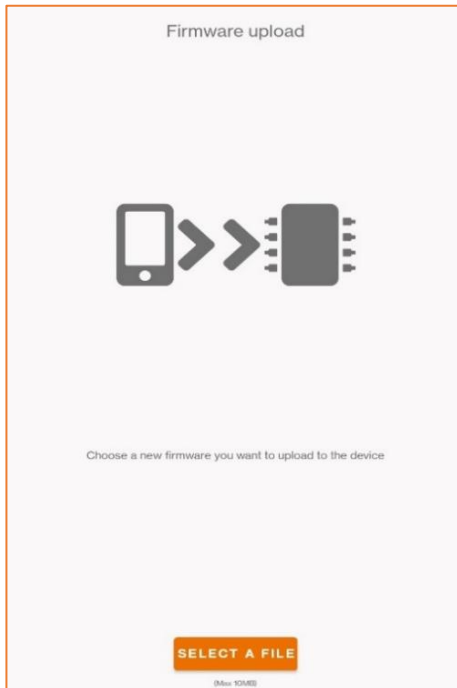

On the firmware page, you can update the firmware of your device.

The requested file must be of type *.bin*.

Once the file has been uploaded, simply follow the on-screen instructions.

ATTENTION:

- ◆ **The upload procedure is irrevocable. Once the upload has started, it will not be possible to pause it.**
- ◆ **If the procedure is interrupted, the firmware will be corrupted, and you will need to repeat the loading procedure.**
- ◆ **At the end of the firmware load, all previously set parameters will be reset to factory defaults.**

If the update is successful and the loaded version is different from the earlier one, the device will flash 10 times on the connected load.

LOADING PARAMETERS

IMPORTANT: The parameters must be written when the device is switched OFF (without input power).

READ



With the app in READ mode, the smartphone will scan the device and show its current configuration on the screen.

WRITE

In WRITE mode, the smartphone will write the parameter configuration set on the screen to the device.

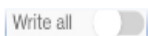

In normal mode (*Write All* switched OFF) the app writes only the parameters that have changed since the previous read. In this mode, the write will only be successful if the serial number of the device matches the one previously read.

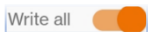

In *Write All* mode, all parameters are written. In this mode, the write will only be successful if the device model matches the one previously read.

It is recommended to activate the *Write All* mode only when you need to replicate the same configuration on many examples of the same model.

WRITE PROTECTION



By the padlock button it is possible to set a lock when writing parameters. A screen will appear for entering a 4-character password. Once this password has been written into the device, all next parameter changes can only be made if the correct password is written on the app's Settings page.

To remove the password lock, simply press the lock key and leave the Password field blank.

WRITE ERROR

After writing the parameters, if the load connected to the device flashes continuously at a frequency of 2 times per second when it is turned ON again, it means that the writing was not successful. Therefore, you will need to perform the following steps:

1. Turn OFF the device.
2. Perform a parameter rewrite.
3. Wait for the write to be successful or for no error messages to appear.
4. Turn the device back ON.

If that doesn't work, you can perform a factory reset by quickly turning the device OFF and ON 6 times.

PRODUCT INFORMATION

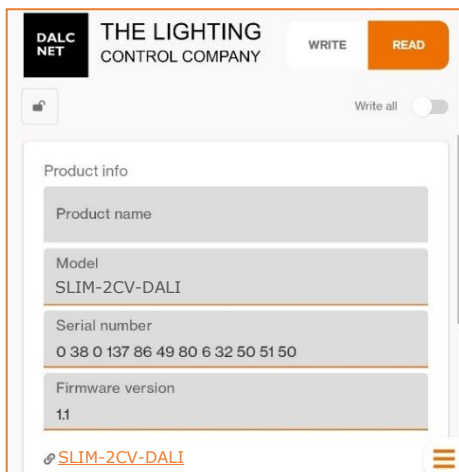

On the *Product Information* screen, you can view a variety of information about the product you are about to configure.

Product Name: User-settable field for easy identification (e.g. Office, Meeting Room, Lobby, etc.). By default, the product name is the same as the Model field.

Model: the model of the device (non-editable field).

Serial Number: uniquely identifies the device (non-editable field).

Firmware Version: shows the firmware version currently loaded on the device (non-editable field).

GENERAL PARAMETERS

The following information can be viewed via LightApp[®].

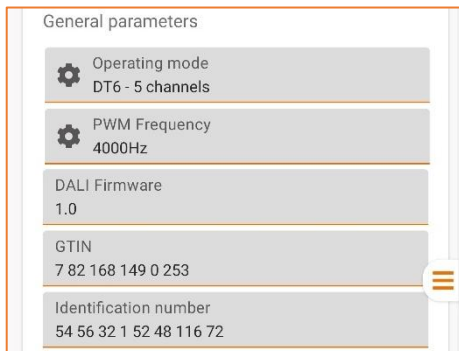

Operating mode: allows you to select the DALI profile DT8 or DT6 (see next paragraph).

PWM Frequency: sets the frequency¹⁰ of the PWM modulation of the output..

DALI Firmware: shows the DALI firmware version currently loaded on the device (non-editable field).

GTIN: the unique DALI code of the product (non-editable field).

Identification Number: serial number of the microcontroller (non-editable field).

OPEN-CIRCUIT AND SHORT-CIRCUIT DETECTION

By the Lamp-Failure command, the DALI protocol allows you to detect situations in which the LED load connected to the output of the SLIM-2CV-DALI may not work as expected, such as an incorrect connection (detecting it as an Open Circuit error) or a defect in the LED load (detecting it as a short circuit).

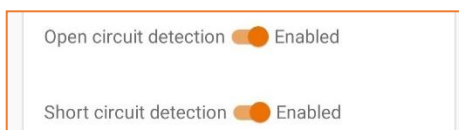

Open Circuit detection: Enables or Disables the Open-Circuit detection. If a very small load is connected to the output of the dimmer, false open-circuits may be detected in some cases. In this case, it is recommended to disable the Open Circuit detection functionality.

Short Circuit function: Enables or Disables the Short-Circuit detection. If a load with a high in-rush current is connected to the dimmer output, in some cases false short-circuits may be detected. In this case, it is recommended to disable the Short Circuit detection function.

¹⁰ In the case of applications under severe thermal conditions, it is advisable to lower the PWM frequency to a minimum (307 Hz).

DALI PARAMETERS

The following parameters can be displayed and configured for each the output channel.

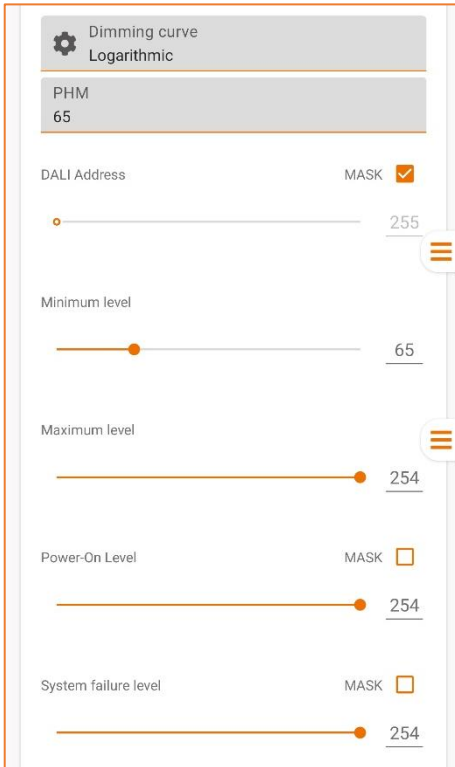

Dimming curve
Logarithmic

PHM
65

DALI Address MASK 255

Minimum level 65

Maximum level 254

Power-On Level MASK 254

System failure level MASK 254



Fade rate 44,7

Fade time
Extended fade time

Fast fade time
25mS

Minimum fast fade time
1

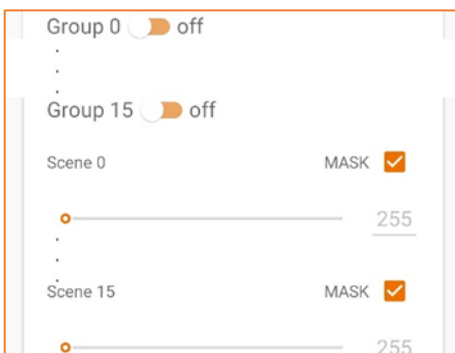

Group 0 off

Group 15 off

Scene 0 MASK 255

Scene 15 MASK 255

Dimming Curve: Sets the dimming curve of the device for operation with remote control. For details on the different curves that can be set, see the §Dimming Curves section of this manual.

PHM: Indicates whether the switched-on device is switchable only (PHM=254) or dimmable (PHM<254) (non-editable field).

DALI Address: Sets the address associated with the device in the DALI network.

Mask: Enables or disables control.

Minimum Level: sets the minimum level of light intensity that can be reached via remote control (default value = 1).

Maximum Level: sets the maximum level of light intensity that can be reached via remote control (default value = 254).

Power-On Level: this is the intensity value to which the output is brought as soon as the device is powered.

Mask: Enables or disables control.

System Failure Level: this is the intensity value to which the output is brought when a system error occurs.

Mask: Enables or disables control.

Fade rate: indicates the rate (in steps/second) at which the output changes in brightness when the UP and DOWN commands are received.

Fade time: sets the time it takes for the output to make a transition from one light intensity level to another.

Fast fade time: sets the amount of time it takes for the output to make a *quick* transition from one light intensity level to another.

Minimum fast fade time: Shows the minimum time for the fast transition (non-editable field).

Group 0-15: allows to associate the device address with one or more groups.

Scene 0-15: allows to pair the device with one or more scenes.

Mask: Enables or disables control.